

Siemens STEP 2000 Course



Switchboards

It's easy to get in STEP!

- 1 Download any course.
Hint: Make sure you download all parts for each course and the test answer form.
- 2 Complete each chapter and its review section
- 3 Print the test answer form, take the final exam and fill in the form.
Hint: The final exam is always at the end of the last part.
- 4 Send your test answer form to EandM for grading. If you achieve a score of 70% or better, we'll send you a certificate of completion! If you have any questions, contact EandM Training at 866.693.2636 or fax 707.473.3190 or training@eandm.com.

Need more information? Contact **EandM** at
866.693.2636
or fax 707.473.3190
or sales@eandm.com
for product information, quotes,
classroom training courses and more.

STEP 2000 Courses distributed by
www.eandm.com



Table of Contents

Introduction	2
Distribution Systems	4
Switchboard Definition	10
Overcurrent Protective Devices	15
Switchboard Construction	20
Service Section.....	28
Service Section Main Disconnect Devices	32
Distribution Section	36
Power Supply Systems	39
Service Entrance Equipment	42
Switchboard Grounding	45
Ground Fault Protection.....	50
Switchboard Ratings.....	54
SB1, SB2, and SB3 Switchboards	57
RCIII Switchboards	61
Super Blue Pennant Switchboards	64
Commercial Metering Switchboards	66
Speciality Service Entrance Switchboards.....	68
Information Needed To Order Switchboards	72
Review Answers.....	74
Final Exam	75

Introduction

Welcome to another course in the STEP 2000 series, **Siemens Technical Education Program**, designed to prepare our distributors to sell Siemens Energy & Automation products more effectively. This course covers **Switchboards** and related products.

Upon completion of **Switchboards** you should be able to:

- Explain the role of switchboards in a distribution system
- Define a switchboard according to the National Electrical Code
- Explain the need for circuit protection
- Identify various components of a switchboard
- Identify various service entrance methods
- Explain the difference between hot and cold sequence in relation to current transformers
- Identify types of main and distribution devices available for Siemens switchboards
- Identify various Siemens switchboards

This knowledge will help you better understand customer applications. In addition, you will be better able to describe products to customers and determine important differences between products. You should complete **Basics of Electricity** and **Molded Case Circuit Breakers** before attempting **Switchboards**. An understanding of many of the concepts covered in these courses is required for **Switchboards**.

If you are an employee of a Siemens Energy & Automation authorized distributor, fill out the final exam tear-out card and mail in the card. We will mail you a certificate of completion if you score a passing grade. Good luck with your efforts.

Clampmatic, Vacu Break, Sensitrip, and Speedfax are registered trademarks of Siemens Energy & Automation, Inc.

ACCESS, Sentron, and Super Blue Pennant are trademarks of Siemens Energy & Automation, Inc.

National Electrical Code[®] and NEC[®] are registered trademarks of the National Fire Protection Association, Quincy, MA 02269. Portions of the National Electrical Code are reprinted with permission from NFPA 70-2002, National Electrical Code Copyright, 2001, National Fire Protection Association, Quincy, MA 02269. This reprinted material is not the complete and official position of the National Fire Protection Association on the referenced subject which is represented by the standard in its entirety.

Underwriters Laboratories Inc. and UL are a registered trademarks of Underwriters Laboratories Inc., Northbrook, IL 60062.

National Electrical Manufacturers Association is located at 2101 L. Street, N.W., Washington, D.C. 20037. The abbreviation "NEMA" is understood to mean National Electrical Manufacturers Association.

Other trademarks are the property of their respective owners.

Distribution Systems

A distribution system is a system that distributes electrical power throughout a building. Distribution systems are used in every residential, commercial, and industrial building.

Residential Distribution

Most of us are familiar with the distribution system found in the average home. Power, purchased from a utility company, enters the house through a metering device. The power is then distributed from a load center to various branch circuits for lighting, appliances, and electrical outlets.

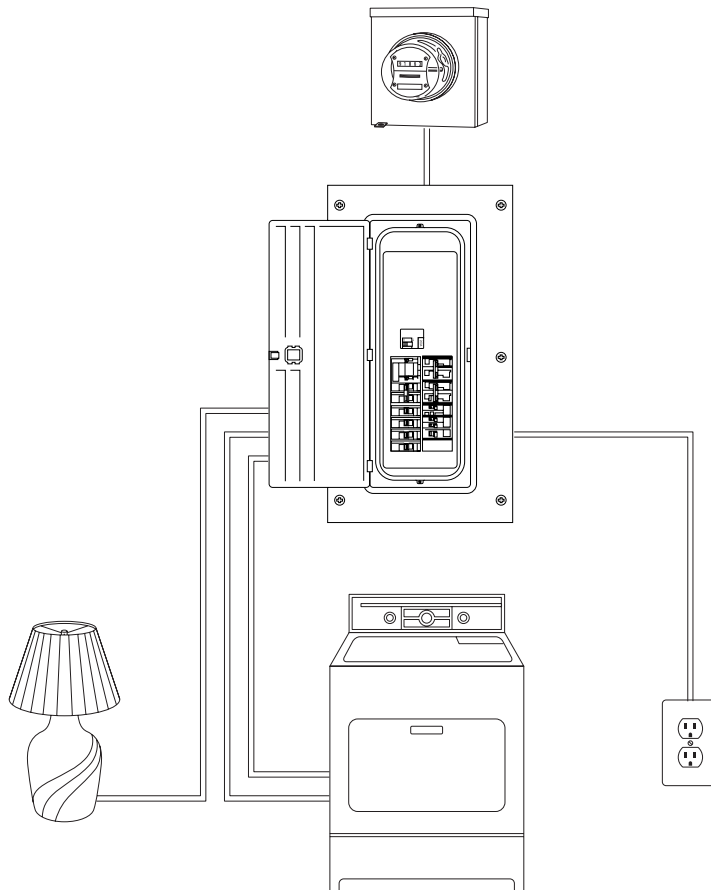

Commercial and Industrial Distribution

Distribution systems used in commercial and industrial locations are more complex. An industrial distribution system consists of metering devices to measure power consumption, main and branch disconnects, protective devices, switching devices to start and stop power flow, conductors, and transformers. Power may be distributed through various switchgear and switchboards, transformers, and panelboards. Good distribution systems don't just happen. Careful engineering is required so that the distribution system safely and efficiently supplies adequate electric service and protection to both present and possible future loads.

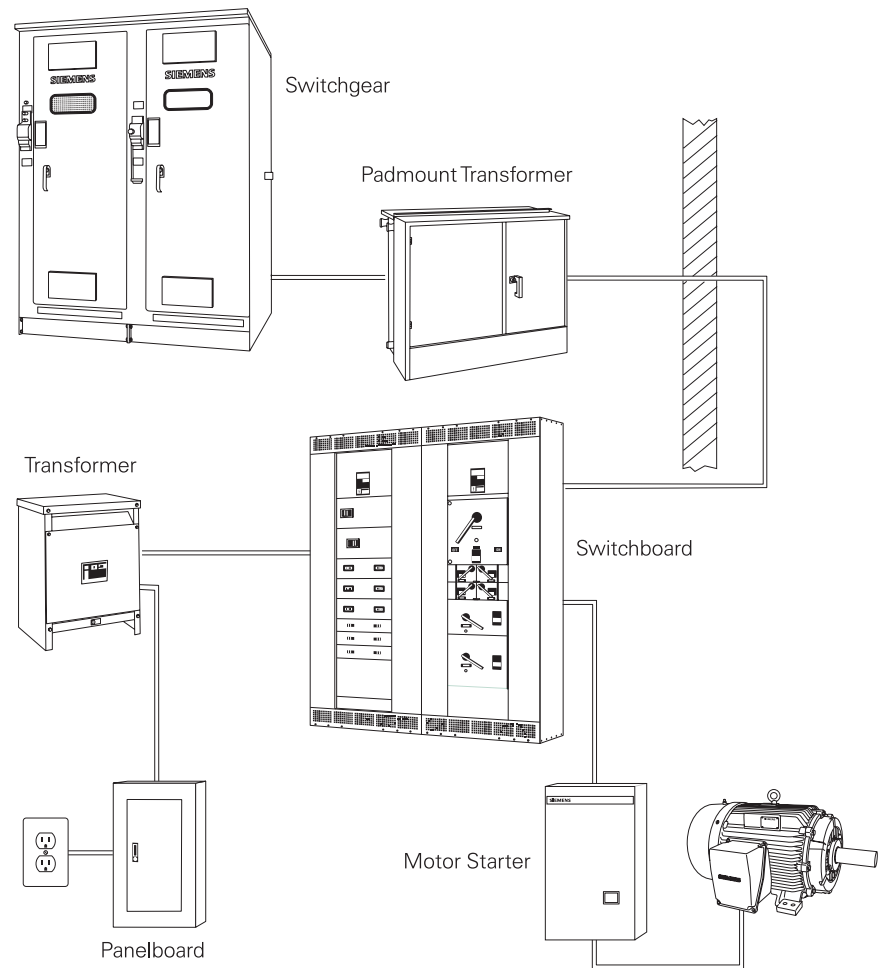

Distribution of Current

Switchboards are used in a building's electrical distribution system. A switchboard divides a large electrical current into smaller currents used to power electrical equipment. Switchboards can be found in applications ranging from small office buildings to large industrial complexes.

Small Office Building

A small office building, for example, might require 120 volts for interior lighting and receptacles, and 208 volts for heating, air conditioning, and exterior lighting. In this example the utility company supplies 208/120 volt, three-phase, four-wire service. The main incoming line is divided into four feeders. The two outer feeders supply power directly to the 208 volt heating and air conditioning units. The two inner feeders are divided into a number of branch circuits. One set of branch circuits supplies power to exterior lighting (208 volts). The second set of branch circuits supplies power to interior lighting and receptacles (120 volts).

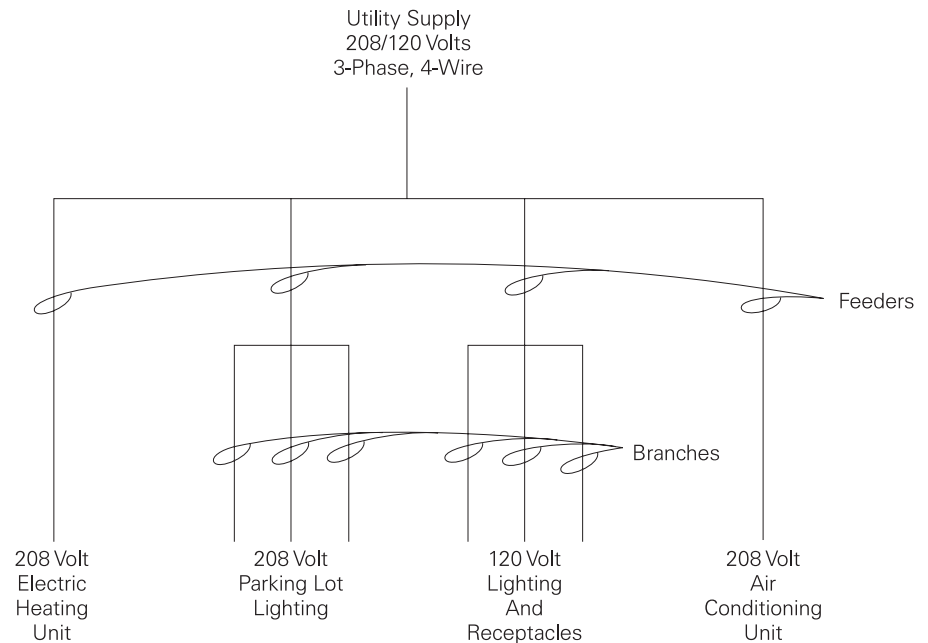

The utility company supplies power from a transformer with a wye connected secondary. The secondary winding of the transformer produces 208/120 VAC. This is referred to as three-phase, four wire (3Ø4W). Single-phase 120 VAC is available between any phase wire and neutral. Single-phase 208 VAC is available between any two phases.

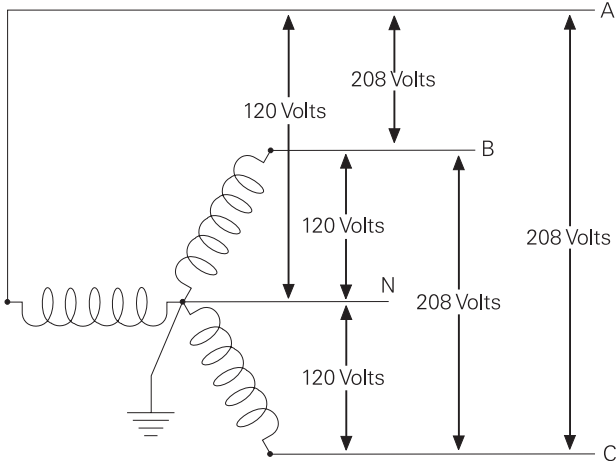

Incoming power is metered by the utility company. In this example power is supplied to the building through a main service disconnect. A switchboard divides the power into four feeders for distribution throughout the building.

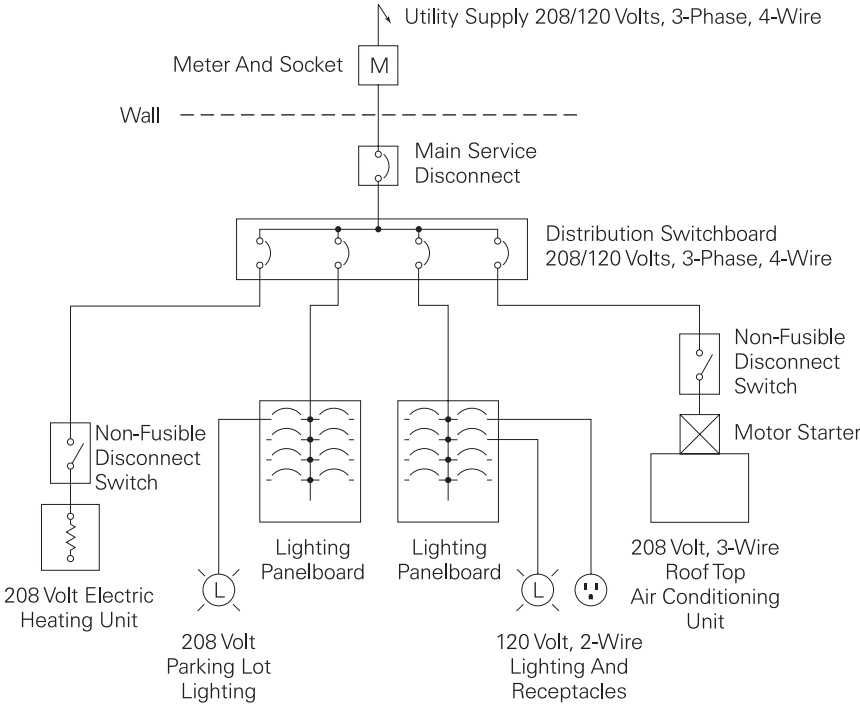

Medium Industrial Plant

Another example of a distribution system is a medium industrial plant. In this example the incoming power is 480/277 volts, three-phase, four-wire. Three feeders are used. The first feeder is used for various types of power equipment. The second feeder supplies a group of 480 VAC motors. The third feeder is used for 120 volt lighting and receptacles.

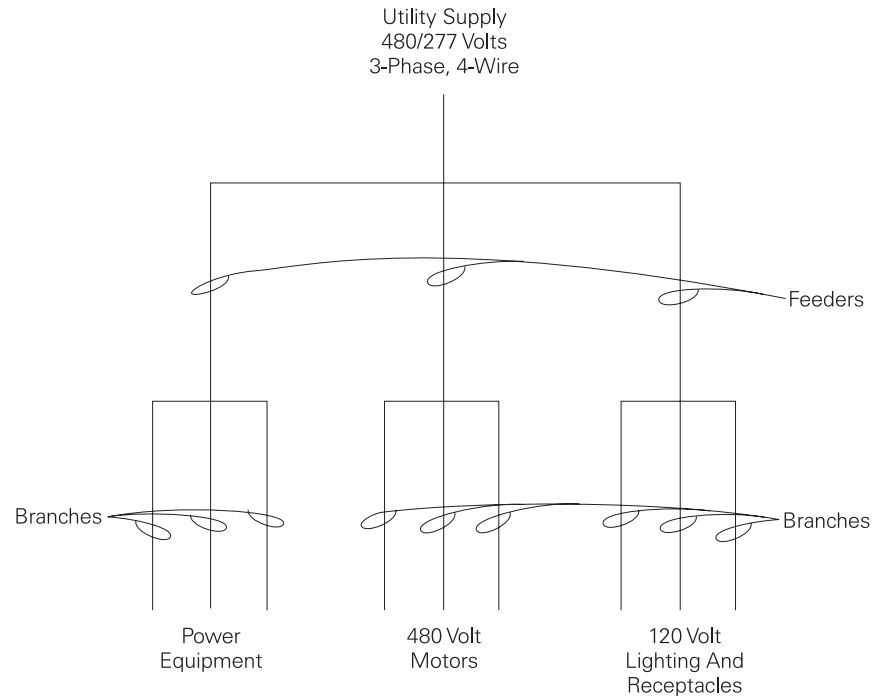

The utility company supplies power from a transformer. The secondary winding of the transformer produces 480/277 VAC.

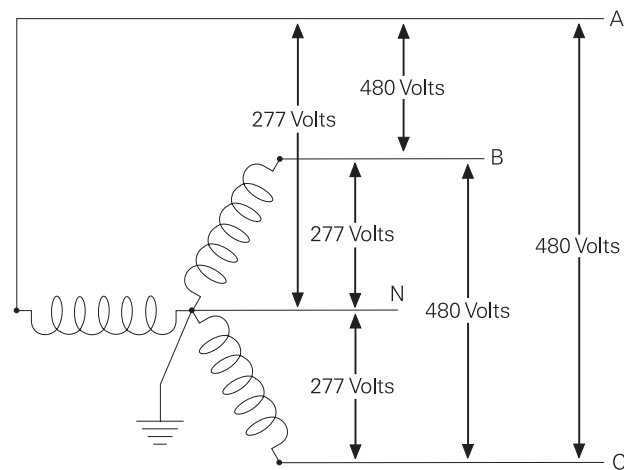

In this example power from the utility company is metered and enters the plant through a distribution switchboard. The switchboard serves as the main disconnecting means. The feeder on the left feeds a distribution switchboard, which in turn feeds a panelboard and a 480 volt, three-phase, three-wire motor. The middle feeder feeds another switchboard, which divides the power into three, three-phase, three-wire circuits. Each circuit feeds a busway run to 480 volt motors. The feeder on the right supplies 208/120 volt power, through a step-down transformer, to lighting and receptacle panelboards. Branch circuits from the lighting and receptacle panelboards supply power for lighting and outlets throughout the plant.

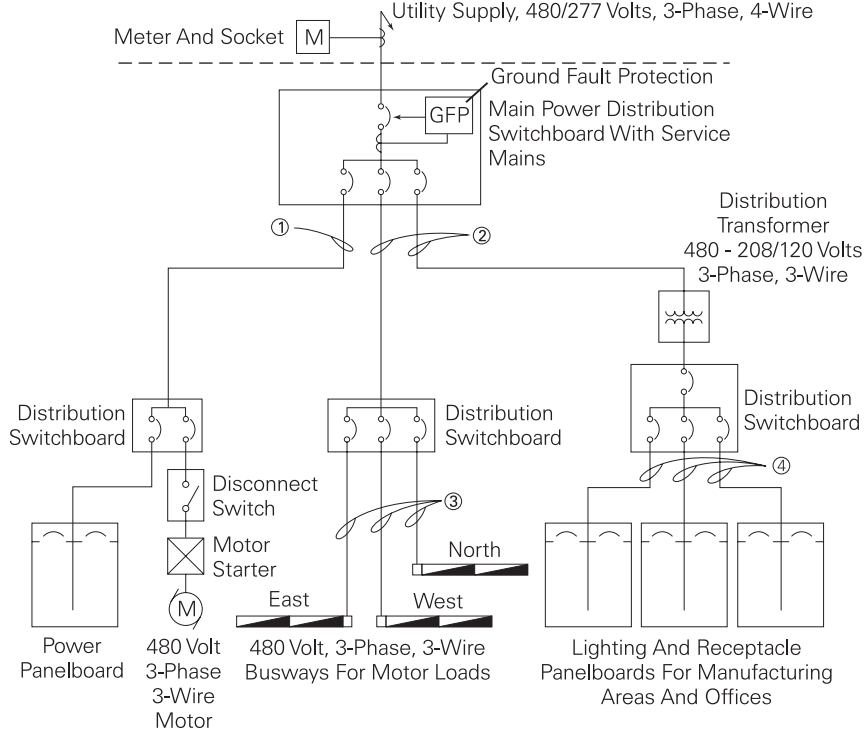

- ① 480/277 Volt 3-Phase, 4-Wire Feeder
- ② 480 Volt 3-Phase, 3-Wire Feeders
- ③ 480 Volt 3-Phase, 3-Wire Circuits
- ④ 208/120 Volt 3-Phase, 4-Wire Circuits

Switchboard Definition

Definition

The *National Electrical Code*[®] (*NEC*[®]) defines a switchboard as a large single panel, frame, or assembly of panels on which are mounted, on the face or back, or both, switches, overcurrent and other protective devices, buses, and usually instruments. Switchboards are generally accessible from the rear as well as from the front and are not intended to be installed in cabinets (Article 100-definitions).

The following drawing illustrates a switchboard made up of a group of two sections. Several overcurrent protective devices (molded case circuit breakers) are mounted on the switchboard.

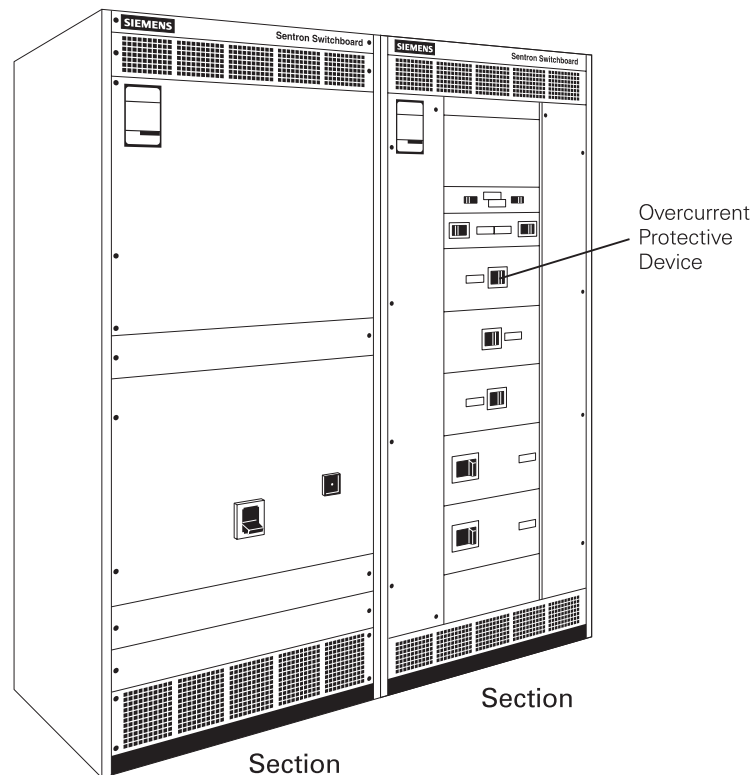

NEC[®] and *National Electrical Code*[®] are registered trademarks of the National Fire Protection Association. Reprinted with permission from NFPA 70-2002, the *National Electrical Code*[®], Copyright© 2001, National Fire Protection Association, Quincy, MA 02269.

Buses are mounted inside the switchboard.

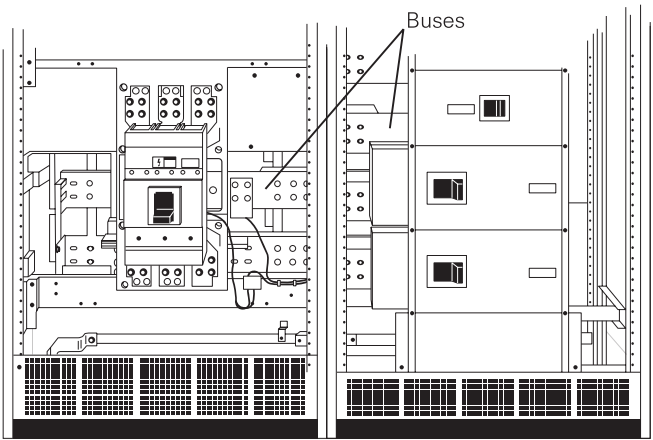

Depending on the design, switchboards may be installed next to a wall or away from the wall to permit accessibility to the rear of the switchboard.

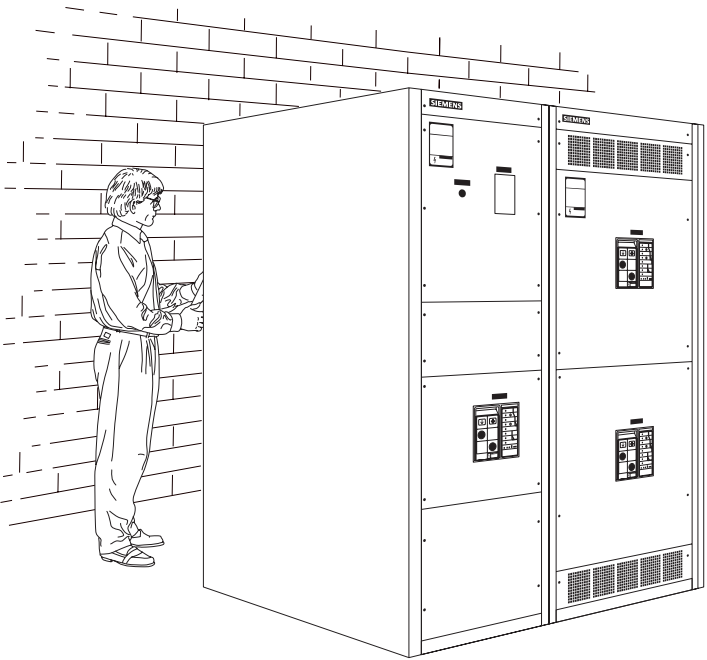

Note: Switchboards are built according to standards set by Underwriters Laboratory (UL 891) and the National Electrical Manufacturers Association (NEMA PB2). Basic requirements for switchboards are also covered by the *National Electrical Code*® Article 408. You are encouraged to become familiar with this material.

NEC® and *National Electrical Code*® are registered trademarks of the National Fire Protection Association.

Instruments/Metering

The *NEC*[®] definition of a switchboard includes instrumentation. Siemens offers a full line of power meters for use in switchboards, which include the 9200, 9300, 9330, 9350, 9500, 9600, and 9700. These meters are compatible with the ACCESS[™] power management and control system. ACCESS is a networked power-monitoring and control system that provides sophisticated power-management capabilities. The flexibility and modularity of the complete ACCESS system make it possible to customize a power-management solution for almost every situation.

Siemens power meters replace multiple traditional analog meters and selector switches, and allow remote monitoring of power-related parameters. Among these are phase voltage and current, line voltage and current, neutral current, kW hours, kW demand, power factor, and line frequency. Data-logging and power-management calculations are easily accomplished using ACCESS and WinPM.

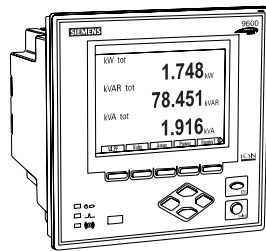

9600

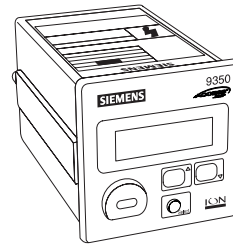

9350

WinPM

WinPM™ is supervisory software designed for monitoring and control of a facility's electrical distribution system. WinPM can monitor an entire electrical system consisting of hundreds of field devices in multiple locations. Alarms can be setup to trigger if a specific value, such as voltage, current, or KW demand, is exceeded. Alarms can alert via audible and visual messages on a PC, fax, or pager message, and/or automatically control a connected device.

Power quality, such as transients, sags, swells, and harmonics, can be monitored and analyzed by viewing triggered waveforms, continuous data sampling, relay trip logs, and setpoint event messages. Historical data logs can be generated to provide load profile information, kilowatt demand usage patterns, harmonic, and power factor trends. These historical data logs can provide trending on any measured value.



The STEP 2000 book, **Power Monitoring and Management with ACCESS**, provides more information on power meters and the ACCESS system.

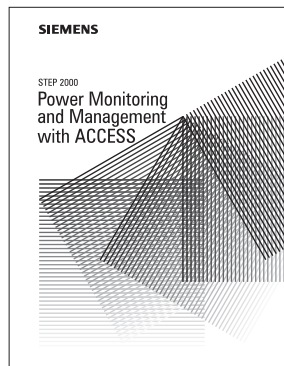

Review 1

1. The phase-to-neutral voltage of a wye-connected transformer with a phase-to-phase voltage of 208 volts is _____ volts.
2. The phase-to-neutral voltage of a wye-connected transformer with a phase-to-phase voltage of 480 volts is _____ volts.
3. According to the *National Electrical Code*[®] definition, switchboards _____ .
 - a are accessible from the front only
 - b are accessible from the rear only
 - c may be accessible from the front and rear
4. Switchboards are built according to standards set by _____ and _____ .
5. Basic requirements for switchboards are given in *NEC*[®] Article _____ .

Overcurrent Protective Devices

Excessive current is referred to as overcurrent. The *National Electrical Code*[®] defines overcurrent as *any current in excess of the rated current of equipment or the ampacity of a conductor. It may result from overload, short circuit, or ground fault* (Article 100-definitions).

Current flow in a conductor always generates heat. The greater the current flow, the hotter the conductor. Excess heat is damaging to electrical components. For that reason, conductors have a rated continuous current carrying capacity or ampacity. Overcurrent protection devices are used to protect conductors and electrical equipment from excessive current flow. These protective devices are designed to keep the flow of current in a circuit at a safe level to prevent the circuit conductors from overheating.

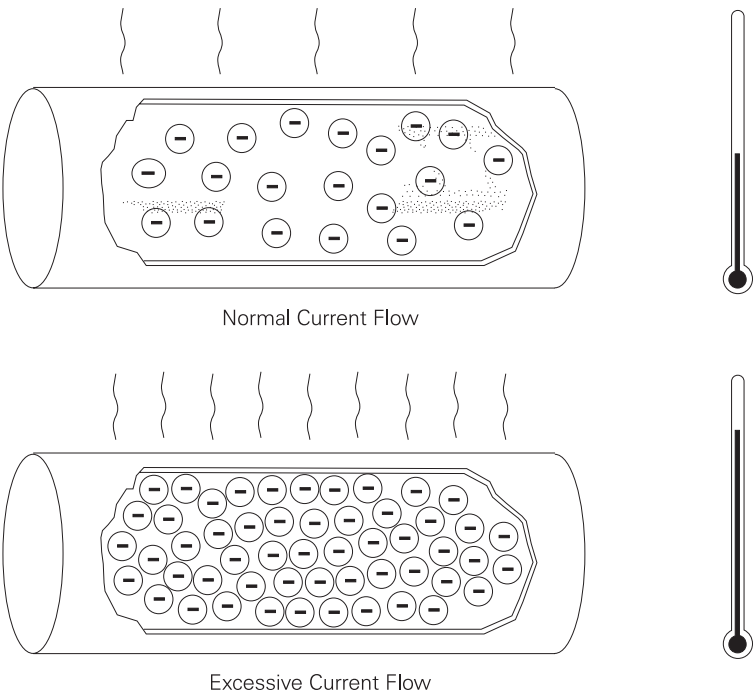

NEC[®] and *National Electrical Code*[®] are registered trademarks of the National Fire Protection Association. Reprinted with permission from NFPA 70-2002, the *National Electrical Code*[®], Copyright© 2001, National Fire Protection Association, Quincy, MA 02269.

Circuit protection would be unnecessary if overloads and short circuits could be eliminated. Unfortunately, overloads and short circuits do occur. To protect a circuit from these currents, a protective device must determine when a fault condition develops and automatically disconnect the electrical equipment from the voltage source. An overcurrent protection device must be able to recognize the difference between overcurrents and short circuits and respond in the proper way. Slight overcurrents can be allowed to continue for some period of time, but as the current magnitude increases, the protection device must open faster. Short circuits must be interrupted instantly.

Fusible Disconnect Switch

A fusible disconnect switch is one type of device used in switchboards to provide overcurrent protection. Properly sized fuses located in the switch open the circuit when an overcurrent condition exists.

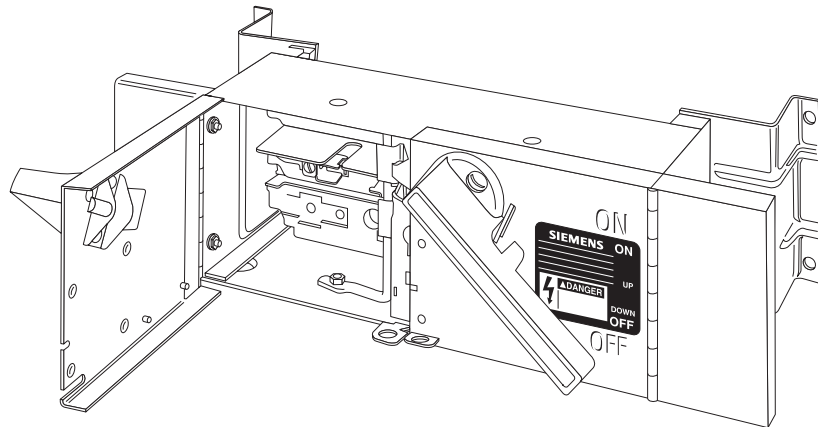

Fuse

A fuse is a one-shot device. The heat produced by overcurrent causes the current carrying element to melt open, disconnecting the load from the source voltage.

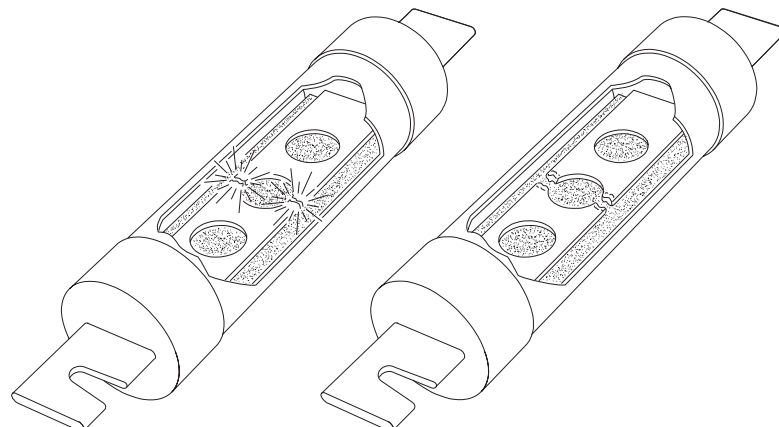

Nontime-Delay Fuses

Nontime-delay fuses provide excellent short circuit protection. When an overcurrent occurs, heat builds up rapidly in the fuse. Nontime-delay fuses usually hold 500% of their rating for approximately one-fourth second, after which the current-carrying element melts. This means that these fuses should not be used in motor circuits which often have inrush currents greater than 500%.

Time-Delay Fuses

Time-delay fuses provide overload and short circuit protection. Time-delay fuses usually allow five times the rated current for up to ten seconds to allow motors to start.

Fuse Classes

Fuses are grouped into classes based on their operating and construction characteristics. Each class has an ampere interrupting capacity (AIC) which is the amount of fault current they are capable of interrupting without destroying the fuse casing. Fuses are also rated according to the maximum continuous current and maximum voltage they can handle. Underwriters Laboratories (UL) establishes and standardizes basic performance and physical specifications to develop its safety test procedures. These standards have resulted in distinct classes of low voltage fuses rated at 600 volts or less. The following chart lists the fuse class and its AIC rating.

Class	Voltage Rating	Ampere Rating	Interrupting Rating (Amps)	Sub Classes	UL Standard
G	300	0-60	100,000		UL 248 5
H	250, 600	0-600	10,000	Renewable Nonrenewable	UL 248 7
J	600	0-600	200,000		UL 248 8
K	250, 600	0-600	50,000, or 100,000, or 200,000	K1 and K5	UL 248 9
L	600	601-6000	200,000		UL 248 10
R	250, 600	0-600	200,000	RK1 and RK5	UL 248 12
T	300	0-1200	200,000		UL 248 15
T	600	0-800	200,000		UL 248 15
CC	600	0-30	200,000		UL 248 4
Plug	125	0-30	10,000	"Edison Base" and Type S	UL 198 F

Class R Fuseholder

An optional Class R fuseholder can be used. The Class R rejection clip contains a pin that permits only the notched Class R fuse to be inserted. This prevents a lower rated fuse from being used.

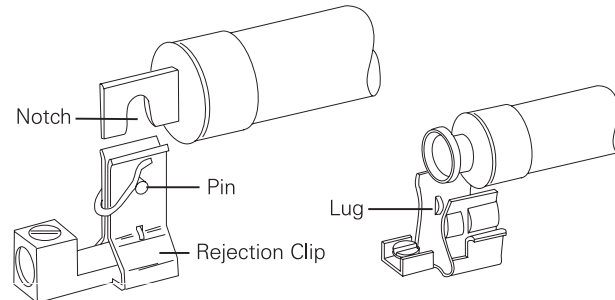

Circuit Breakers

Another device used for overcurrent protection is a circuit breaker. The *National Electrical Code*[®] defines a circuit breaker as *a device designed to open and close a circuit by nonautomatic means and to open the circuit automatically on a predetermined overcurrent without damage to itself when properly applied within its rating.*

Circuit breakers provide a manual means of energizing and de-energizing a circuit. In addition, circuit breakers provide automatic overcurrent protection of a circuit. A circuit breaker allows a circuit to be reactivated quickly after a short circuit or overload is cleared.

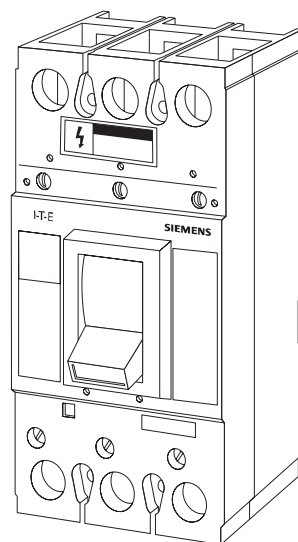

NEC[®] and *National Electrical Code*[®] are registered trademarks of the National Fire Protection Association. Reprinted with permission from NFPA 70-2002, the *National Electrical Code*[®], Copyright© 2001, National Fire Protection Association, Quincy, MA 02269.

Ampere Rating

Like fuses, every circuit breaker has a specific ampere, voltage, and fault current interruption rating. The ampere rating is the maximum continuous current a circuit breaker can carry without exceeding its rating. As a general rule, the circuit breaker ampere rating should match the conductor ampere rating. For example, if the conductor is rated for 20 amps, the circuit breaker should be rated for 20 amps. Siemens breakers are rated on the basis of using 60° C or 75° C conductors. This means that even if a conductor with a higher temperature rating were used, the ampacity of the conductor must be figured on its 60° C or 75° C rating.

There are some specific circumstances when the ampere rating is permitted to be greater than the current carrying capacity of the circuit. For example, motor and welder circuits can exceed conductor ampacity to allow for inrush currents and duty cycles within limits established by *NEC*[®].

Generally the ampere rating of a circuit breaker is selected at 125% of the continuous load current. This usually corresponds to the conductor ampacity which is also selected at 125% of continuous load current. For example, a 125 amp circuit breaker would be selected for a load of 100 amps.

Voltage Rating

The voltage rating of the circuit breaker must be at least equal to the circuit voltage. The voltage rating of a circuit breaker can be higher than the circuit voltage, but never lower. For example, a 480 VAC circuit breaker could be used on a 240 VAC circuit. A 240 VAC circuit breaker could not be used on a 480 VAC circuit. The voltage rating is a function of the circuit breaker's ability to suppress the internal arc that occurs when the circuit breaker's contacts open.

Fault Current Interrupting Rating

Circuit breakers are also rated according to the level of fault current they can interrupt. When applying a circuit breaker, one must be selected to sustain the largest potential short circuit current which can occur in the selected application. Siemens circuit breakers have interrupting ratings from 10,000 to 200,000 amps. To find the interrupting rating of a specific circuit breaker refer to the Speedfax catalog.

Switchboard Construction

There are several components that make up a switchboard. Switchboards consist of a frame, overcurrent protective devices, buses, instrumentation, and outer covers.

Frame

The frame of the switchboard houses and supports the other components. The typical Siemens switchboard frame is 90 inches high and 38 inches wide. Optional height of 70 inches and widths of 32 inches and 46 inches are available.

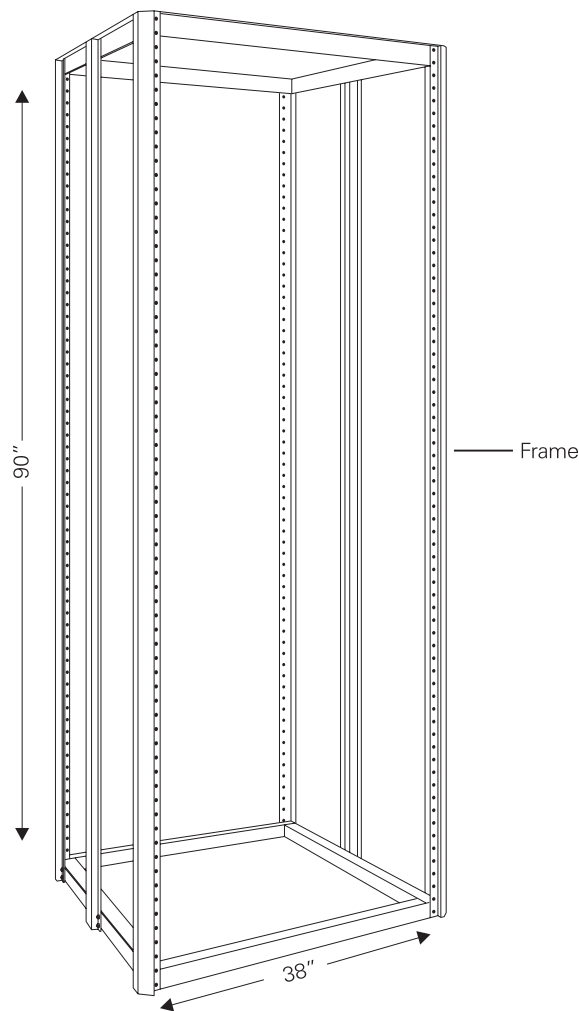

Bus

A bus is a conductor that serves as a common connection for two or more circuits. It is represented schematically by a straight line with a number of connections made to it. *NEC*[®] article 408.3 states that *bus bars shall be located so as to be free from physical damage and shall be held firmly in place.*

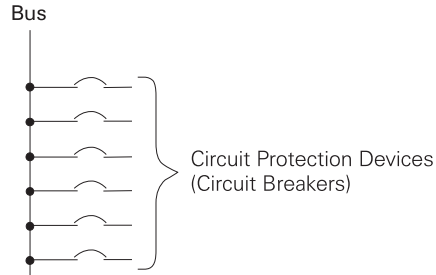

NEMA Arrangement

Bus bars are required to have phases in sequence so that an installer can have the same fixed-phase arrangement in each termination point in any switchboard. This is established by NEMA (National Electrical Manufacturers Association). It is possible to have a non-NEMA phase sequence which would have to be marked on the switchboard. Unless otherwise marked, it is assumed that bus bars are arranged according to NEMA. The following diagram illustrates accepted NEMA phase arrangements.

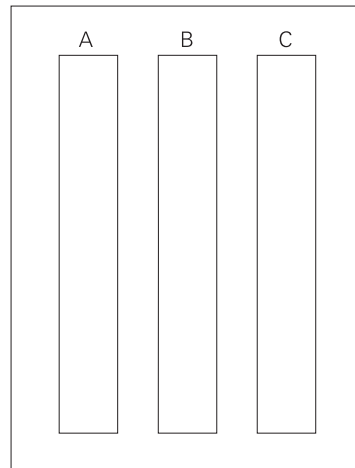

Vertical

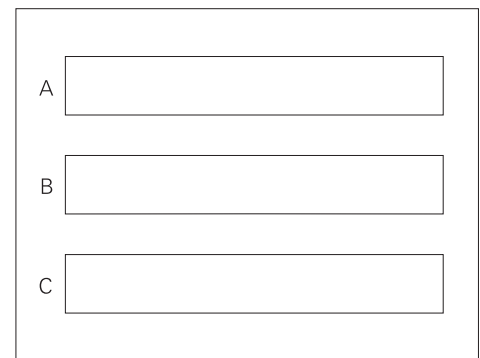

Horizontal

NEC[®] and *National Electrical Code*[®] are registered trademarks of the National Fire Protection Association. Reprinted with permission from NFPA 70-2002, the *National Electrical Code*[®], Copyright© 2001, National Fire Protection Association, Quincy, MA 02269.

Buses are mounted within the frame. Horizontal buses are used to distribute power to each switchboard section. Vertical buses are used to distribute power via overcurrent devices to the load devices. Standard bus bars on Siemens switchboards are made of aluminum, but copper bus bars are available as an option.

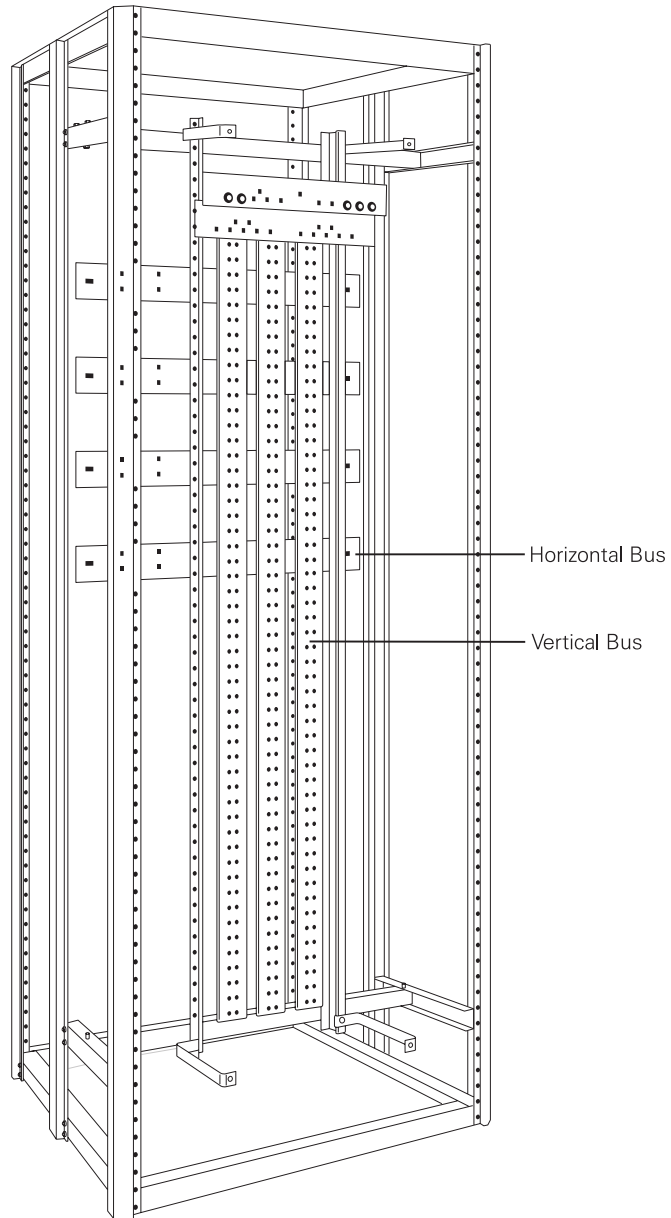

The following rear view drawing of a switchboard illustrates vertical and horizontal bus bar connection. (The vertical phase bus bars appear to be in reverse order because they are viewed from the rear. The bus bars are in the proper NEMA order as viewed from the front.) A bus connector makes a mechanical and electrical connection between a vertical bus bar and its corresponding horizontal bus bar. In this drawing the connector can be clearly seen on the neutral bus. Compression lugs provided on this switchboard accept properly sized incoming power cables.

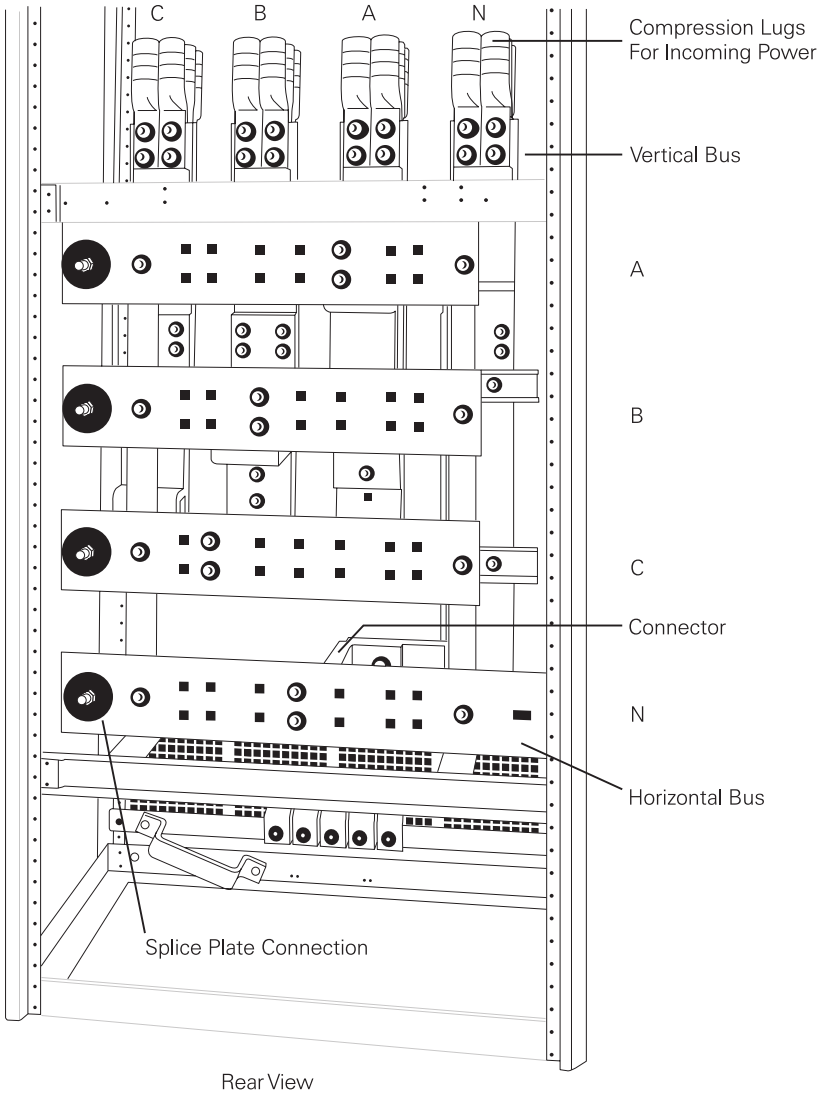

Splice Plates

Splice plates are used to join the horizontal bus bars of adjoining switchboard sections, as illustrated in the following rear view drawing. To make additional distribution sections easier to install when they are needed, the horizontal bus is extended and predrilled to accept splice plates. A new section is set flush against an existing section. The old and new sections are connected together with splice plates.

The extended horizontal bus is also referred to as through-bus. The load requirements in downstream distribution sections is generally less than in upstream service sections. The capacity of the through-bus is tapered, or reduced downstream as load falls off. The through-bus is tapered to a minimum of one-third the ampacity of the incoming service mains. Full-capacity, or non-tapered, through-bus is available as an option. The ampacity of non-tapered through-bus remains constant throughout the switchboard.

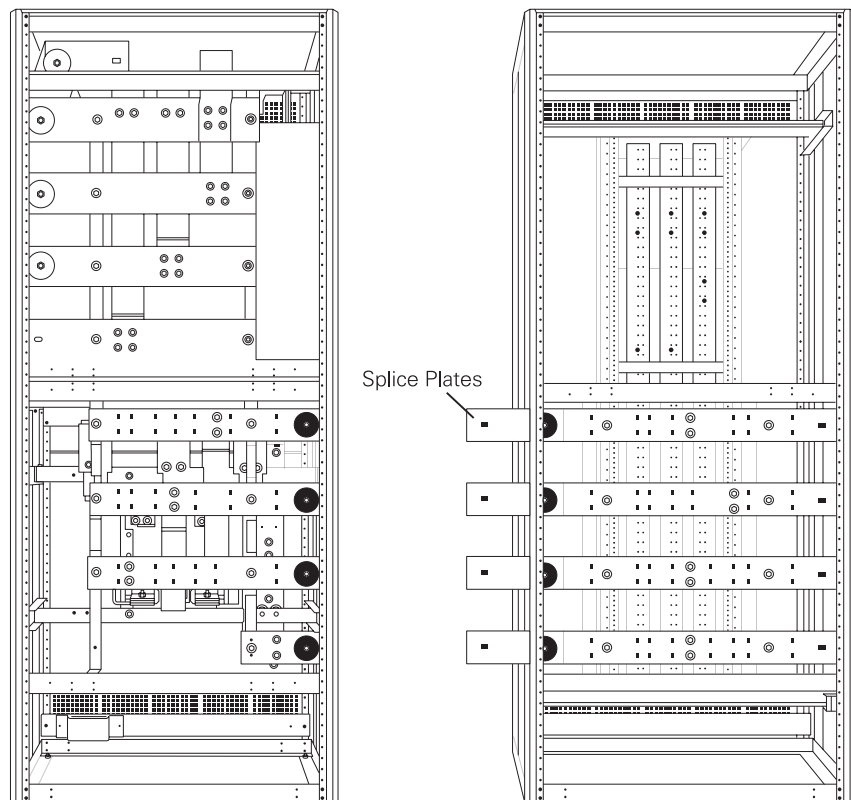

Rear View

Protective Devices

Operator components are mounted on the front side of the switchboard. This includes protective devices, such as circuit breakers and disconnect switches, which can be covered by a trim panel. These devices are mounted to the bus bars using straps connected to the line side of the devices.

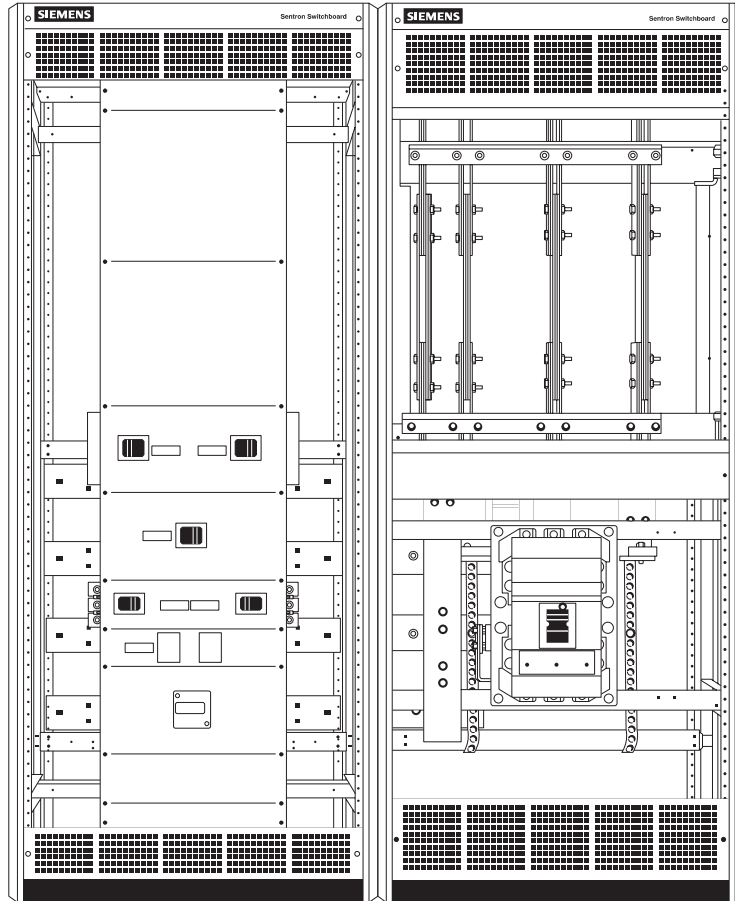

Front View

Dead Front and Trim

Cover panels are installed on the switchboard so that no live parts are exposed to the operator. This is referred to as dead front. The panels are also used as trim to provide a finished look to the switchboard. A product information label identifies the switchboard type, catalog number, and voltage and amperage rating.

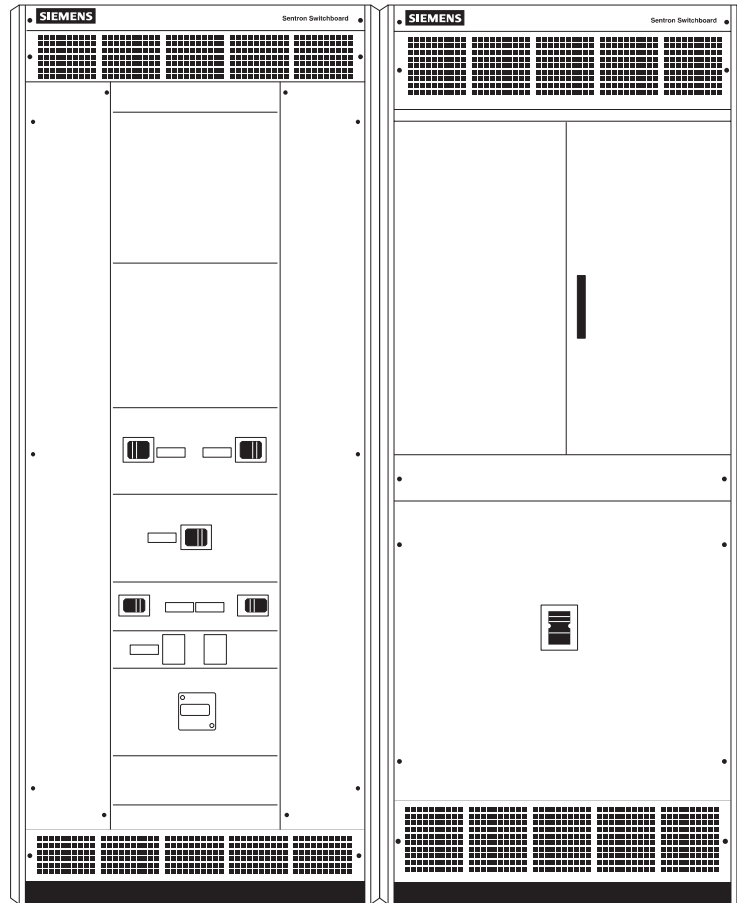

Pictorial

Switchboards can be shown pictorially using block diagrams and/or one-line diagrams. The following pictorial illustrates a two section switchboard.

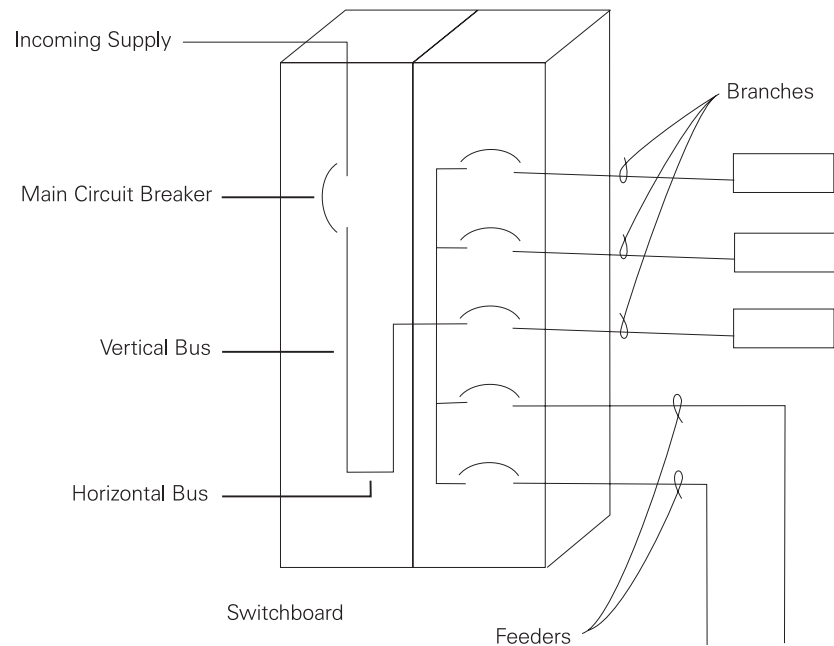

Review 2

1. The rated continuous current carrying capacity of a conductor is known as _____ .
2. _____ - delay fuses provide overload and short circuit protection.
3. The interrupting rating of a Class R fuse is _____ amps.
4. The height of the standard Siemens switchboard frame is _____ inches.
5. A _____ is a conductor that serves as a common connection for two or more circuits.
6. _____ plates join horizontal buses between two adjoining switchboard sections.
7. The extended horizontal bus that connects one section to another is referred to as _____ - _____