

## Siemens STEP 2000 Course



# Basics of Electrical Products

### It's easy to get in STEP!

- 1 Download any course.  
*Hint: Make sure you download all parts for each course and the test answer form.*
- 2 Complete each chapter and its review section
- 3 Print the test answer form, take the final exam and fill in the form.  
*Hint: The final exam is always at the end of the last part.*
- 4 Send your test answer form to EandM for grading. If you achieve a score of 70% or better, we'll send you a certificate of completion! If you have any questions, contact EandM Training at 866.693.2636 or fax 707.473.3190 or [training@eandm.com](mailto:training@eandm.com).

Need more information? Contact **EandM** at  
866.693.2636  
or fax 707.473.3190  
or [sales@eandm.com](mailto:sales@eandm.com)  
for product information, quotes,  
classroom training courses and more.

**STEP 2000 Courses distributed by**  
[www.eandm.com](http://www.eandm.com)



# Table of Contents

Introduction .....	2
Siemens Energy & Automation, Inc.....	4
Electric Power.....	6
Residential Applications.....	11
Commercial Applications .....	20
Industrial Applications.....	36
Manufacturing Applications .....	47
Discrete Parts Manufacturing .....	49
Assembly Processes .....	56
Batch and Continuous Processes .....	64
Pictorial Glossary .....	70
Review Answers.....	118
Final Exam .....	119

# Introduction

Welcome to another course in the STEP 2000 series, **Siemens Technical Education Program**, designed to prepare our distributors to sell Siemens Energy & Automation products more effectively. This course covers **Basics of Electrical Products**.

Upon completion of **Basics of Electrical Products**, you should be able to:

- Explain how power is distributed from a power distribution plant to various residential, commercial, and industrial facilities
- Explain how Siemens products are used in basic residential, commercial, and industrial applications
- Explain the similarities and differences between load centers, panelboards, switchboards, switchgear, and secondary unit substations
- Identify various Siemens products used in discrete parts manufacturing, assembly, batch processing, and continuous processing
- Identify various Siemens products by trade name

This knowledge will help you better understand customer applications. In addition, you will be better prepared to discuss electrical products and systems with customers. You should complete **Basics of Electricity** before attempting **Basics of Electrical Products**. Once you have completed **Basics of Electrical Products**, you should complete or review any of the other STEP 2000 courses that are relevant to your work. The general information provided in **Basics of Electrical Products** will help you better understand the specific product details in the remaining STEP 2000 courses.

If you are an employee of a Siemens Energy & Automation authorized distributor, fill out the final exam tear-out card and mail in the card. We will mail you a certificate of completion if you score a passing grade. Good luck with your efforts.

EQ, instabus, WinCC, SITOP, SINUMERIK, SIMODRIVE, SIMOREG, and SIMATIC are registered trademarks of Siemens Energy & Automation, Inc.

Uni-Pak, Sentron, ACCESS, Super Blue Pennant, Medallion, ESP100, INNOVA PLUS, System 89, and PCS are trademarks of Siemens Energy & Automation, Inc.

National Electrical Code<sup>®</sup> and NEC<sup>®</sup> are registered trademarks of the National Fire Protection Association, Quincy, MA 02269. Portions of the National Electrical Code are reprinted with permission from NFPA 70-2002, National Electrical Code Copyright, 2001, National Fire Protection Association, Quincy, MA 02269. This reprinted material is not the complete and official position of the National Fire Protection Association on the referenced subject which is represented by the standard in its entirety.

Underwriters Laboratories Inc. and UL are registered trademarks of Underwriters Laboratories Inc., Northbrook, IL 60062.

National Electrical Manufacturers Association is located at 2101 L Street, N.W., Washington, D.C. 20037. The abbreviation "NEMA" is understood to mean National Electrical Manufacturers Association.

MS-DOS, Windows, and Windows NT are registered trademarks of Microsoft, Inc.

Other trademarks are the property of their respective owners.

# Siemens Energy & Automation, Inc.

## Company Overview

Siemens Energy & Automation (SE&A) is one of a number of companies owned by Siemens AG. Siemens AG has its headquarters in Munich, Germany, and is one of the world's largest suppliers of electrical and electronic products, systems, and associated services. Siemens companies operate in the United States under the financial umbrella of Siemens Corporation. These companies sell equipment for use in a vast array of industries and applications.

SE&A sells a broad range of products that are used in residential, commercial, and industrial applications. A generic listing of the products sold by SE&A sales force and authorized distributors is shown below.

- AC Motors, Pumps, and Compressors
- Busway
- Circuit Breakers
- Control Components
- Safety Switches
- Human Machine Interfaces (HMI)
- Industrial Networks
- Industrial Personal Computers
- Load Centers
- Metering
- Motion Controls and Servo Drives
- Motor Control Centers
- Panelboards
- Power Monitoring and Management Systems
- Power Supplies
- Process Automation Systems
- Programmable Logic Controllers (PLCs)
- Radio Frequency Identification System
- Software Solutions
- Switchboards
- Switchgear
- Transformers
- Variable Speed Drives

## **Key to Understanding SE&A Products**

Depending upon your experience with electrical and electronic products, you may find the generic listing to be either unintelligible or straightforward. When this list is expanded into the literally thousands of specific products sold by SE&A, even the most experienced professionals may be dazed by the seeming complexity. As diverse as this product listing would be, however, there are some common concepts.

- These products use electrical power and, in many cases, control the flow of energy to other products or systems.
- These products are most commonly used in residential, commercial, and industrial applications.

In order to help you better understand SE&A products, this course will look at where many of these products fit in the flow of energy in sample residential, commercial, and industrial applications. The flow of energy from the electric utility will be discussed only briefly; however, keep in mind that many of the products listed above are also used by electric utilities. In addition, the products of other Siemens companies, especially Siemens Westinghouse Power Corporation and Siemens Power Transmission & Distribution, are used extensively by these utilities.

By better understanding where electrical products fit in the flow of energy, you can better understand the physical and electrical requirements of these products.

# Electric Power

Power, originating at a power generating plant, is distributed to residential, commercial, and industrial customers through various transmission lines and substations.



## Power Sources

There are several sources used to produce power. Coal, oil, and uranium are fuels used to convert water into steam which in turn drives a turbine. Some utilities also use gas turbines, or both gas and steam turbines, for combined cycle operation. The output shaft of the turbine is connected to an AC generator. The AC generator is rotated by the turbine. It is the AC generator which converts the mechanical energy into electrical energy.

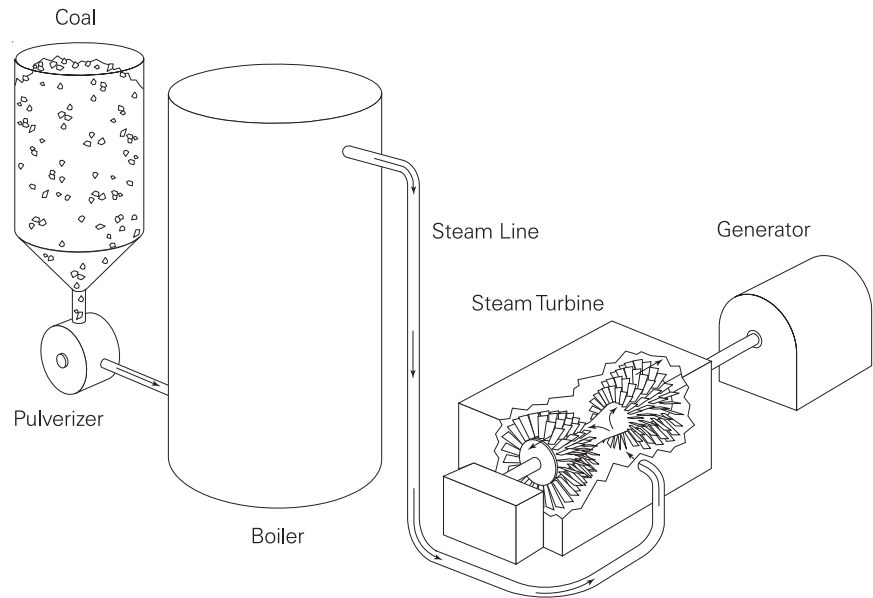

## Hydroelectric Power

Hydroelectric power plants use mechanical energy from falling water to turn the turbine.

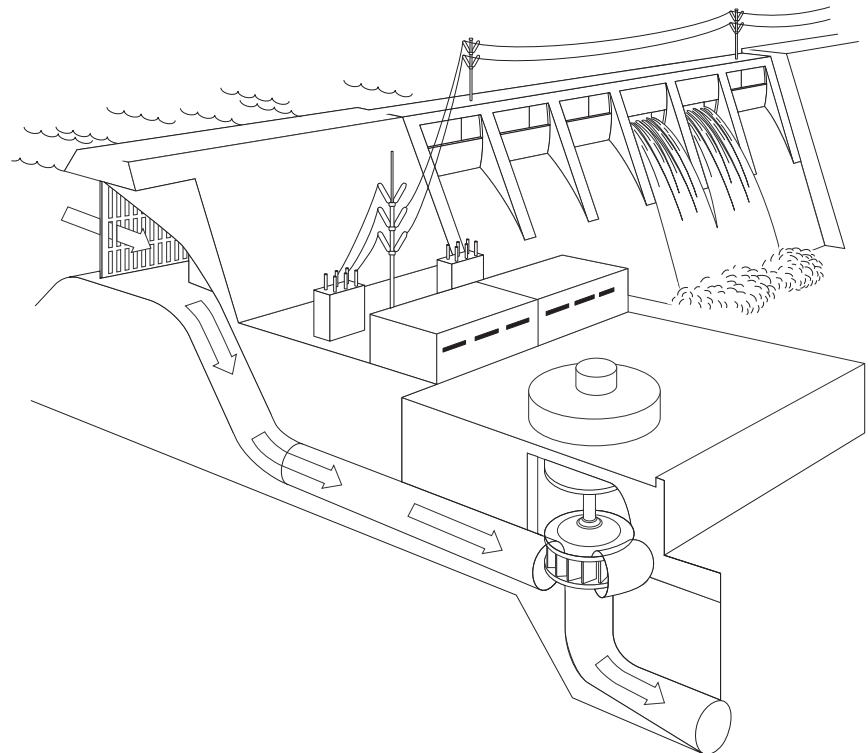



## AC Generators

AC generators operate on the theory of electromagnetic induction. This simply means that when conductors are moved through a magnetic field a voltage is induced into the conductors. A basic generator consists of a magnetic field, an armature, slip rings, brushes, and some type of resistive load. An armature is any number of conductive wires (conductors) wound in loops which rotate through the magnetic field. For simplicity, one loop is shown.

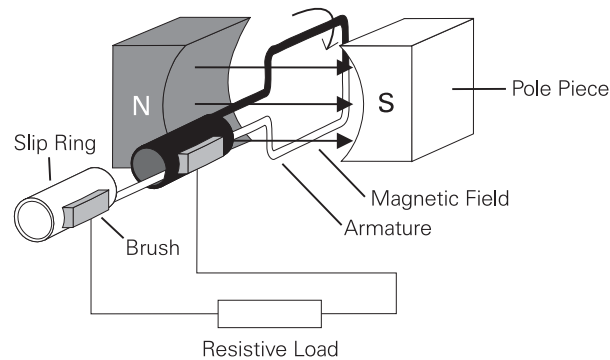

If the rotation of the AC generator were tracked through a complete revolution of  $360^\circ$ , it could be seen that during the first quarter of a revolution voltage would increase until it reached a maximum positive value at  $90^\circ$ . Voltage would decrease during the second quarter of a revolution until it reached zero at  $180^\circ$ . During the third quarter of a revolution, voltage would increase in the opposite direction until it reached a maximum negative value at  $270^\circ$ . During the last quarter of a revolution, voltage would decrease until it reached zero at  $360^\circ$ . This is one complete cycle or one complete alternation between positive and negative. If the armature of the AC generator were rotated 3600 times per minute (RPM) we would get 60 cycles of voltage per second, or 60 hertz.

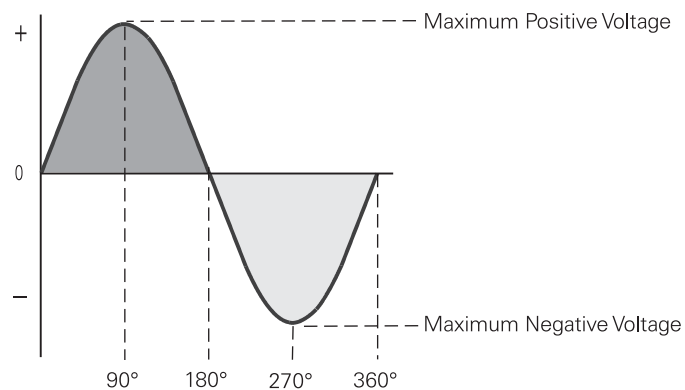

## Energy Transfer

The role of the generator just described is to change mechanical energy into electrical energy. In order for this energy to be useful, however, it must be transmitted to the utility's customers via transmission lines. The most efficient way to do this is to increase the voltage while at the same time reducing the current. This is necessary to minimize the energy lost in heat on the transmission lines. These losses are referred to as  $I^2R$  (I-squared-R) losses since they are equal to the square of the current times the resistance of the power lines. Once the electrical energy gets near the end user, the utility will need to step down the voltage to the level needed by the user.

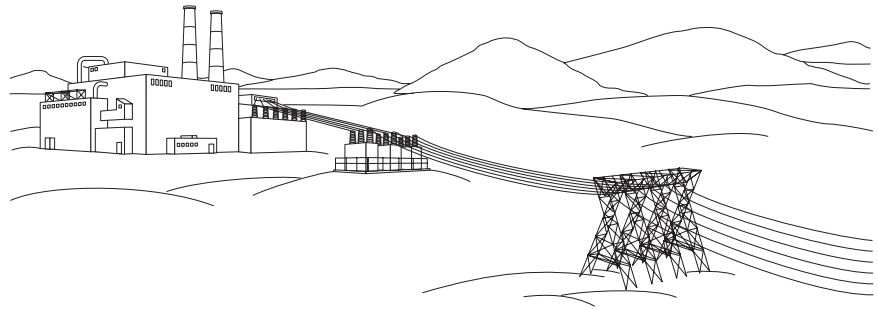

## Transformers

The device that utilities use to step up the voltage at the generator end and step down the voltage at the user end is called a transformer. The transformer transfers energy from a primary coil to a secondary coil by mutual induction. The AC generator provides electrical power to the primary coil. The magnetic field produced by the primary coil induces a voltage into the secondary coil which supplies power to the connected load. The load in this case would be the entire electrical distribution network including all residential, commercial, and industrial customers. A step-up transformer is used when it is desirable to step voltage up from one level to another. A 1:2 step-up transformer, for example, would be used to step 120 volts up to 240 volts. A 2:1 step-down transformer would be used to step 240 volts down to 120 volts.

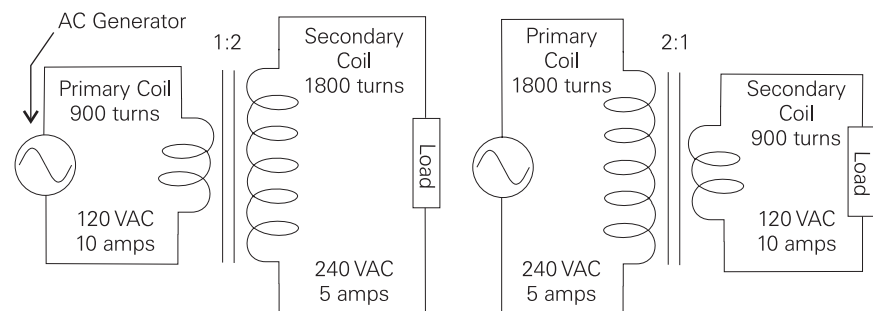

Step-Up Transformer

Step-Down Transformer

## Three-Phase Voltage

For simplicity, the generator and transformers shown so far have been single-phase devices. While single-phase power is needed for many applications, utilities generate and transmit three-phase power. In a three-phase system, the generator produces three voltages. Each voltage phase rises and falls at the same frequency (60 Hz in the U.S., 50 Hz in many other countries); however, the phases are offset from each other by  $120^\circ$ .

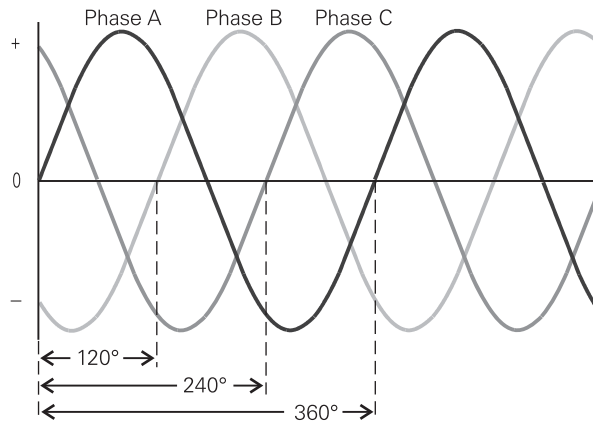

## Three-Phase Transformers

Transformers used with three-phase power require three interconnected coils in both the primary and the secondary. These transformers can be connected in either a wye or a delta configuration. The type of transformer and the actual voltage depend on the requirements and capability of the power company and the needs of the customer. The following illustration shows the secondary of a wye-connected transformer and the secondary of a delta-connected transformer.

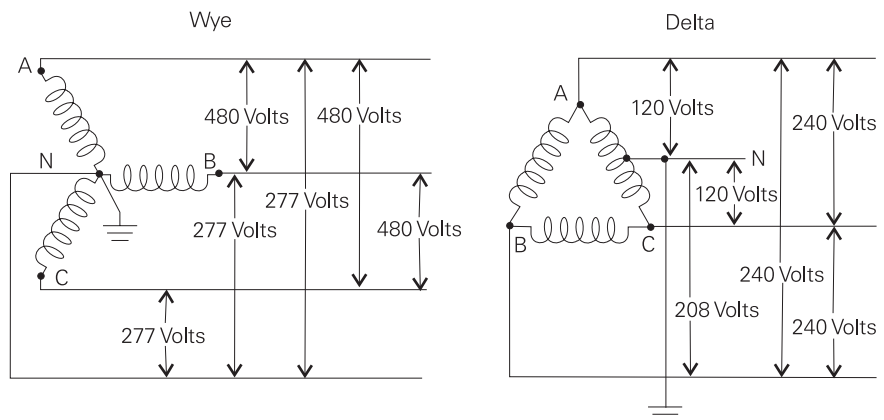

A - B	480 volts
B - C	480 volts
C - A	480 volts
A - N	277 volts
B - N	277 volts
C - N	277 volts

A - B	240 volts
B - C	240 volts
C - A	240 volts
A - N	120 volts
B - N	208 volts
C - N	120 volts

# Residential Applications

Power, generated at a power plant, then stepped up to a high transmission voltage is brought to a local substation. Here, it is stepped down to a lower distribution voltage. When it reaches its final destination at a residential customer, it is stepped down to 240 volts. Only single-phase power is used in a typical residential application.

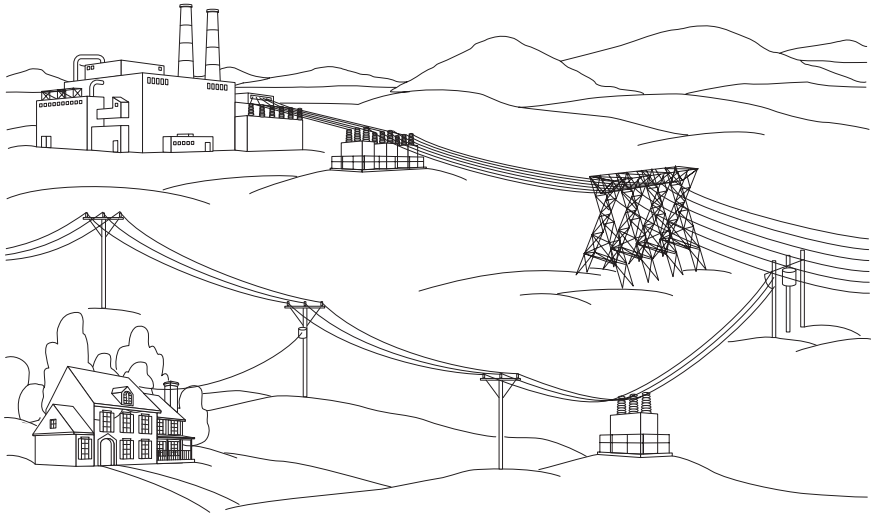

## Power Supply

The most common supply system used in residential applications today is a single-phase, three-wire supply system. In this system, there are 120 volts between either hot wire and neutral and 240 volts between the two hot wires. The 120-volt supply is used for general-purpose receptacles and lighting. The 240 volt supply is used for heating, cooling, cooking, and other high-demand loads.

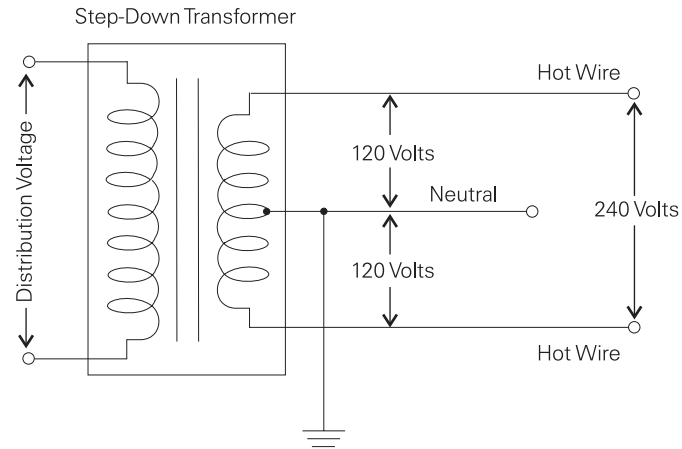

## Service Entrance

Power, purchased from a utility company, enters the house through a metering device and connects to a load center. This is the service entrance. Residential service can come from an overhead utility transformer or from a lateral service run underground.

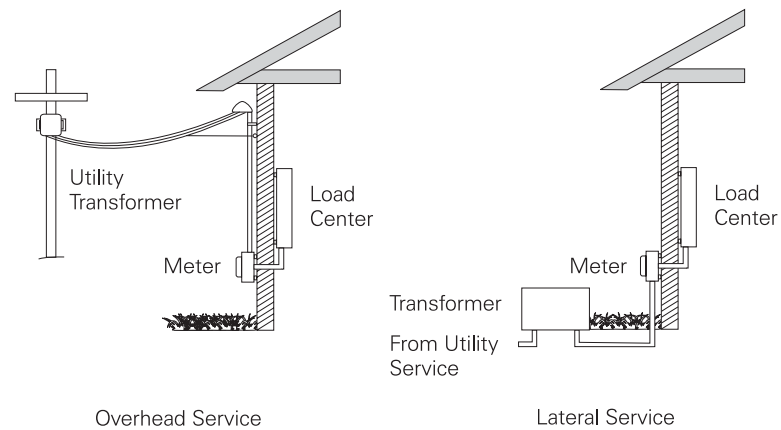

## Meter Sockets

Most of us are familiar with the watt-hour meter located outside our homes. The watt-hour meter is used by the power company to determine how much electricity has been consumed for billing purposes. Siemens manufactures single-position meter sockets for residential use.

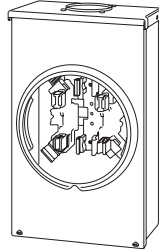

## Meter Mains and Meter Combinations

Meter mains and meter combinations are similar. Meter mains incorporate space for a watt-hour meter (supplied by the utility company) and a main service disconnect within the same enclosure. Meter combinations incorporate space for a watt-hour meter and circuit breaker space for electrical distribution in a residence. These types of load centers are also used as trailer service panels. Meter combinations are primarily found on the West Coast but are also becoming popular in other areas of the country.

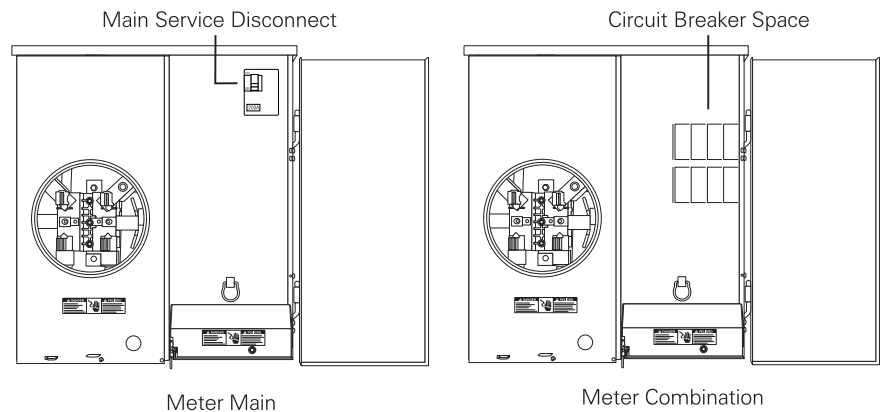

## Modular Meter Centers Metering Systems

Modular meter centers are used for multi-family dwellings such as duplexes or apartment buildings. These are used in conjunction with Siemens load centers. Modular meter centers are available with two to six meter compartments.

Metering systems are another option for multi-family dwellings. These are self-contained systems with two to six meter compartments. Individual branch circuit breakers for tenants are located in a separate compartment adjacent to the meter socket.

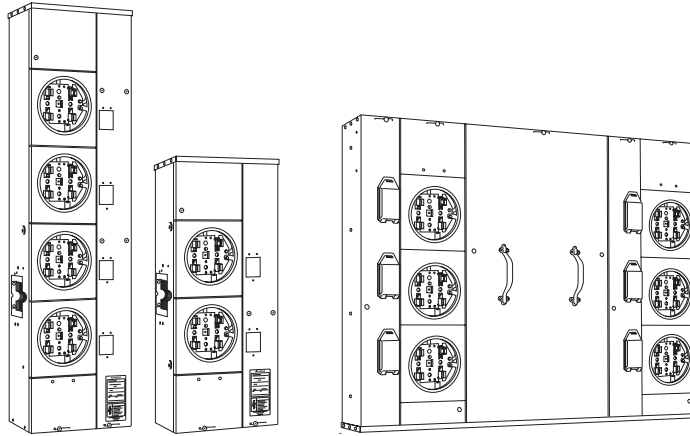

Modular Meter Centers

Metering System

## Distribution

The incoming power then goes to a load center which provides circuit control and overcurrent protection. The power is distributed from the load center to various branch circuits for lighting, appliances, and electrical outlets.

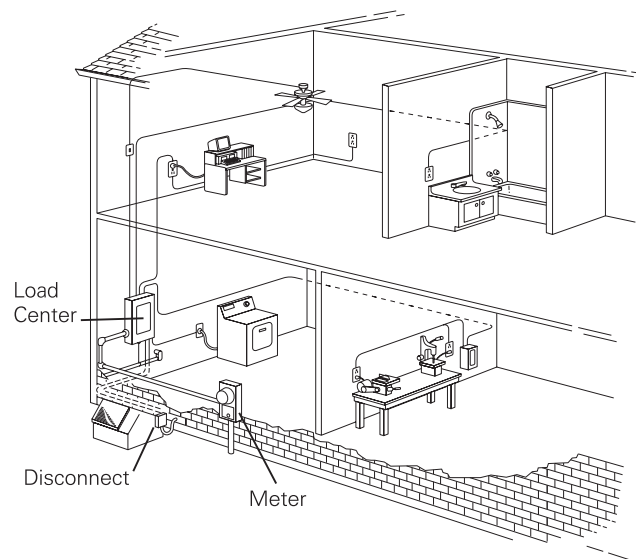

## Load Centers

The term load center is an industry term used to identify a panelboard used in certain applications. Load centers are typically rated 225 amps or less and 240 volts maximum and are intended for use in residential applications. A typical load center consists of an enclosure, interior, and trim. Circuit breakers are mounted in the interior to provide circuit protection and control for light, heat, and power circuits.

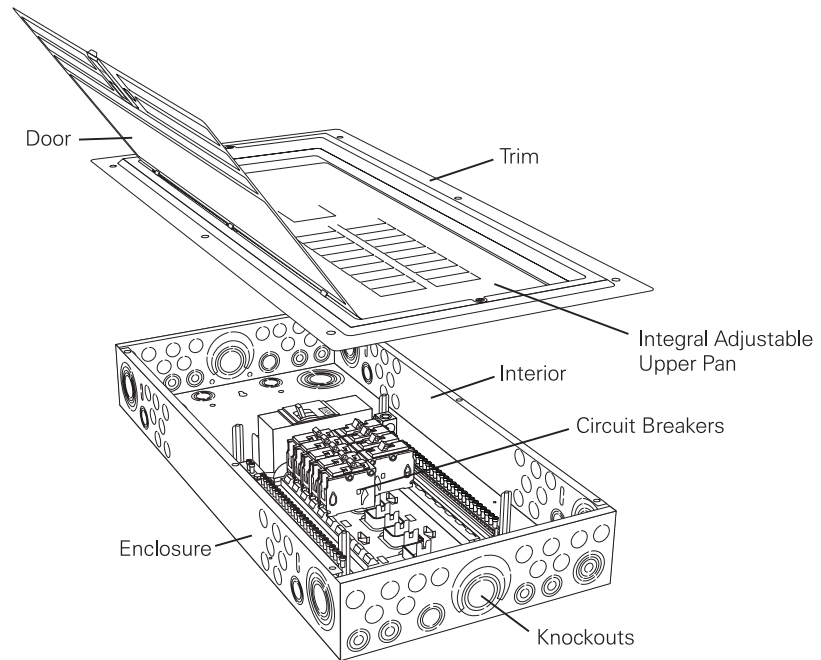

## Circuit Breakers

Circuit breakers provide a manual means of energizing and de-energizing a circuit. In addition, circuit breakers provide automatic overcurrent protection of a circuit. Siemens residential circuit breakers are available with current ratings from 15-125 amps and a voltage rating of 120/240 volts. In residential applications, single-pole breakers protect 120 volt circuits; two-pole breakers protect 240 volt circuits.

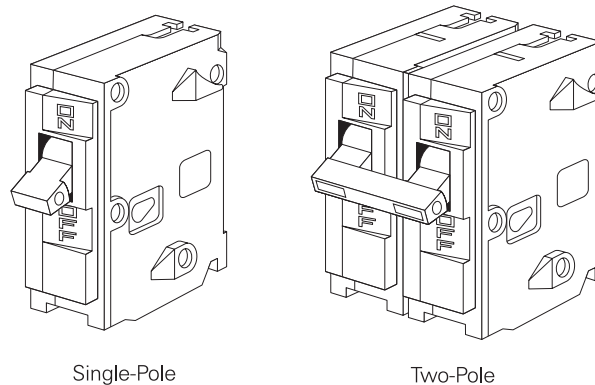

Single-Pole

Two-Pole



## Circuit Breaker/ Surge Arrester

Siemens manufactures special types of circuit breakers for load center use. The Siemens circuit breaker/surge arrester mounts in a load center similarly to a conventional circuit breaker. This device protects electronic equipment, such as televisions or computers, from electrical surges on the system. Surges can come from electrical equipment, switching, or lightning.

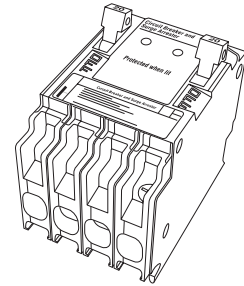
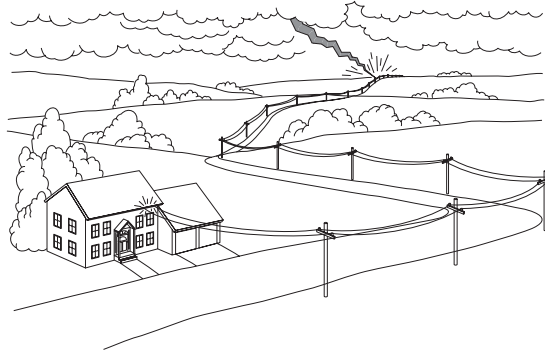

Surge Arrester

## GFCI Circuit Breaker

The ground fault circuit interrupter (GFCI) is required on certain residential receptacles, such as bathroom receptacles, receptacles located within six feet of a kitchen sink, and outdoor receptacles. The GFCI is designed to interrupt a circuit when a ground fault occurs. Often the GFCI is mounted at the receptacle. When this is not feasible, a Siemens GFCI circuit breaker is installed in the load center.

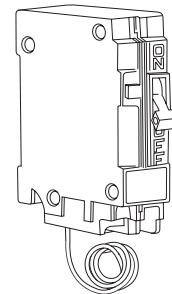
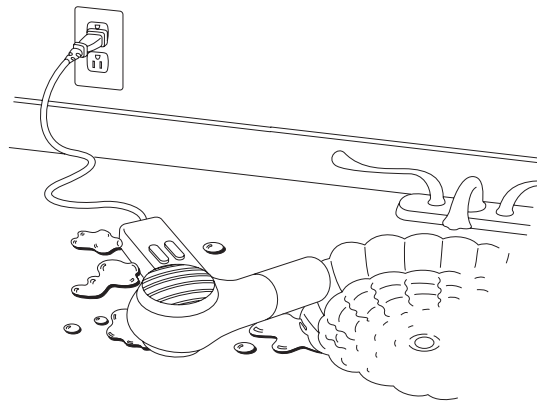

GFCI

## AFCI Circuit Breaker

GFCI devices are designed to protect a person from getting a shock when touching an ungrounded appliance. Arc Fault Circuit Interrupters (AFCI), in comparison, protect against a fire being started from an unintended arc. An arc fault occurs when a current-carrying conductor has an arcing condition to ground or another conductor. An AFCI device is intended to provide protection from the effects of arc faults by recognizing the characteristics unique to arcing and de-energizing the circuit when an arc fault is detected. The arc generated will cause the AFCI to trip. Arcs normally generated from electric equipment such as a light switch or power drill will not cause the AFCI to trip.

Arc-Fault Circuit Interrupter protection was first introduced in the 1999 *National Electrical Code*<sup>®</sup>. *NEC*<sup>®</sup> Article 210.12 and has an effective date of 2002. This requirement applies to all branch circuits that supply 125-volt, single-phase, 15- and 20-amp receptacle outlets installed in dwelling unit bedrooms.

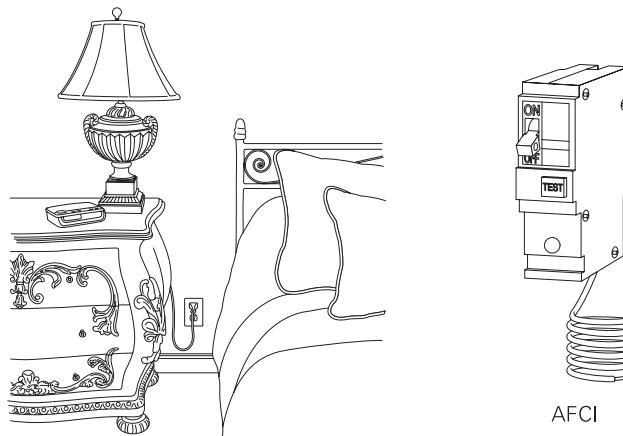

## Enclosed Circuit Breakers and Disconnects

Siemens also manufactures circuit breaker enclosures and fused, non-fused, and molded case switch disconnects.

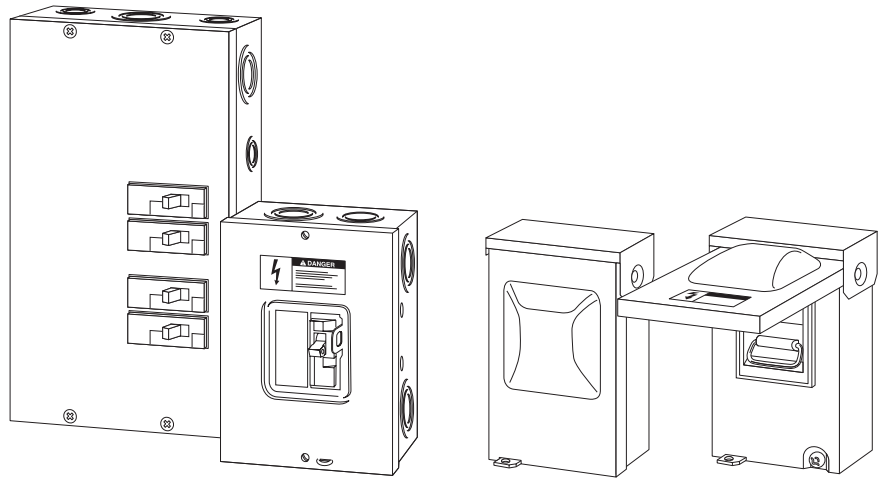

Enclosed Circuit Breaker

Enclosed Disconnect

Enclosed circuit breakers and disconnects provide a convenient means of disconnecting power to allow for the service of equipment such as an air conditioner located downstream from a service entrance load center.

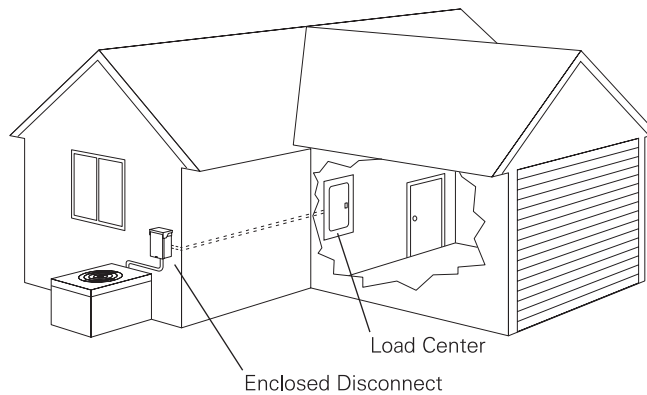

## Review 1

1. A \_\_\_\_\_ is a device that converts mechanical energy into electrical energy.
2. A transformer that increases the voltage from primary to secondary is called a \_\_\_\_\_ transformer.
3. Phases are offset by \_\_\_\_\_ degrees in a three-phase system.
4. \_\_\_\_\_ volts is used for general-purpose receptacles and lighting in residential applications.
5. \_\_\_\_\_ is a type of electrical service that is run underground.
6. Modular meter centers can be supplied with two to \_\_\_\_\_ meter compartments.
7. The circuit breaker/ \_\_\_\_\_ \_\_\_\_\_ is a type of circuit breaker manufactured by Siemens that protects electronic equipment from electrical surges.
8. A \_\_\_\_\_ is required on certain residential receptacles such as bathroom receptacles and receptacles located within six feet of a kitchen sink.