

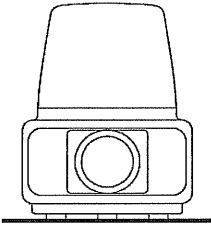
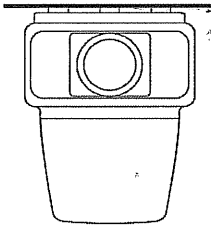
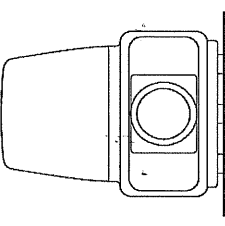

# Specifications

| MODEL                           | #RT-24□-□ FC015  | #RT-120□-□ FC015          | #RT-200□-□ FC015         |            |
|---------------------------------|--|---------------------------|--------------------------|------------|
| Rated Voltage                   | 24V DC   | 120V AC (50/60Hz)         | 200V AC (50/60Hz)        |            |
| Voltage Range                   | 21~27V DC  | 108~132V AC               | 180~240V AC              |            |
| Power Consumption               | Max.24W  | Max.32W                   | Max.30W                  |            |
| Maximum Sound Pressure Level    | 105dB or more<br>Condition for determination: Fit the product on the plate of □300mm, and measure the level with the sound 5."Rapid Hi-Lo" at the distance of 1m from the center the product, in the front direction.<br>※The sound pressure level may be lower depending on the Sound, usage environment, and supplied voltage.   |                           |                          |            |
| Volume                          | adjustable : Min~Max   |                           |                          |            |
| Input Method                    | Level hold input (Sound is played while COM wire and CH wire are short-circuited)  |                           |                          |            |
| CH Input                        | Bit input (When you select the sound group of G from A) / Binary input (When you select the sound group of H)  |                           |                          |            |
| Number of channels              | Bit input : 8 / Binary input : 32  |                           |                          |            |
| Starting time                   | 300msec or less (both Operation by CH signal and Operation by turning on the power)  |                           |                          |            |
| Priority Order for the Channels | CH8(Blue) > CH7(Green) > CH6(Orange) > CH5(Purple) > CH4(Light Green) > CH3(Pink) > CH2(Yellow) > CH1(Sky Blue)  |                           |                          |            |
| Test Play                       |  CH1 is playing by turning on select switch 4   |                           |                          |            |
| Flashing Cycle                  | 115±30 Flashes per minute  | 105±30 Flashes per minute | 95±30 Flashes per minute |            |
| Bulb                            | 24V 20W (G18/BA15S)  | 12V 15W (G18/BA15S)       |                          |            |
| Operating Temperature Range     | -20~+50°C  |                           |                          |            |
| Relative Humidity               | 85%RH or lower (No Condensation)   |                           |                          |            |
| Mounting of Product             | <div style="display: flex; justify-content: space-around; align-items: flex-end;"> <div style="text-align: center;"> <br/>           Normal direction: ○<br/>           Indoor: ○ / Outdoor: ○         </div> <div style="text-align: center;"> <br/>           Reverse direction: ×         </div> <div style="text-align: center;"> <br/>           Lateral direction: ×         </div> </div>  |                           |                          |            |
| Protection Rating               | IP65(KEMA examination passing goods)   |                           |                          |            |
| Insulation Resistance           | 1MΩ and above ( At 500V DC ) (between current-carrying metal parts and non-current-carrying metal part .)  |                           |                          |            |
| Dielectric Strength             | 500V AC for 1 min.   | 1000V AC for 1 min.       | 1500V AC for 1 min.      |            |
| Resistance to Vibration         | 19.6m/s <sup>2</sup><br>30Hz, Back and forth 2h·Right and Left 2h·Up and down 4h   |                           |                          |            |
| Mass                            | 2.0kg±10%  | 2.5kg±10%                 |                          |            |
| Model No. Configuration         | <div style="display: flex; justify-content: space-around; align-items: center;"> <div style="text-align: center;"> <b>#RT - 24</b><br/>           ■ Rated Voltage<br/>           24 : DC 24V<br/>           120 : AC 120V<br/>           200 : AC 200V         </div> <div style="text-align: center;"> <b>A - R</b><br/>           ■ Sound Type<br/>           A : Atype<br/>           C : Ctype<br/>           D : Dtype<br/>           E : Etype         </div> <div style="text-align: center;"> <b>FC015</b><br/>           ■ Dome Color<br/>           R : Red<br/>           Y : Yellow<br/>           G : Green<br/>           B : Blue         </div> <div style="text-align: center;">           ■ Tokupo No.         </div> </div> |                           |                          |            |
| Remarks                         | <p>•RT-24□ complies with the EC DIRECTIVE and indicates CE marking.</p> <p>•PATLITE Corporation has not applied for permission to use certain copyrighted music or songs recorded in our audible of A,C and D types out side of Japan therefore, please contact the local copyright association for permission before using the product in case this product is used outside of JAPAN.</p> <p>Audible products of E type is recommended for use outside of Japan as this model does not include copyrighted music of songs, and this permission is not required.</p> <div style="text-align: right; margin-top: 20px;">  </div>                           |                           |                          |            |
| RT-FC015-A18A-1.3               |  | APP.BY                    | CHK.BY                   | DGN.BY     |
| <b>PATLITE Corporation</b>      |  | M.Yoshida                 | M.Yoshida                | T.Fujiwara |
|                                 |  | 29.Dec.'09                | 29.Dec.'09               | 18.Dec.'09 |

# Specifications

## Sound List

|       |       | Sound List                    |                               |                               |                               |                   |                               |                        |            |                |                              |                     |                 |                                   |                                   |                                   |                                   |                  |                  |                    |               |                |                |                                |                               |                               |                               |                               |                               |        |                 |                   |                    |                                   |             |                          |                        |                    |                    |                          |                          |              |                          |                           |                  |                   |              |                          |                    |             |             |             |             |                               |                       |                             |                   |                     |            |                      |           |              |              |              |              |                |                    |                    |                                  |                 |                  |               |                |  |  |
|-------|-------|-------------------------------|-------------------------------|-------------------------------|-------------------------------|-------------------|-------------------------------|------------------------|------------|----------------|------------------------------|---------------------|-----------------|-----------------------------------|-----------------------------------|-----------------------------------|-----------------------------------|------------------|------------------|--------------------|---------------|----------------|----------------|--------------------------------|-------------------------------|-------------------------------|-------------------------------|-------------------------------|-------------------------------|--------|-----------------|-------------------|--------------------|-----------------------------------|-------------|--------------------------|------------------------|--------------------|--------------------|--------------------------|--------------------------|--------------|--------------------------|---------------------------|------------------|-------------------|--------------|--------------------------|--------------------|-------------|-------------|-------------|-------------|-------------------------------|-----------------------|-----------------------------|-------------------|---------------------|------------|----------------------|-----------|--------------|--------------|--------------|--------------|----------------|--------------------|--------------------|----------------------------------|-----------------|------------------|---------------|----------------|--|--|
| Atype | 01    | Beep (slow intermittent horn) | 07                            | Synthesized Piano             | 13                            | Fur Elise         | 19                            | Mary had a little Lamb | 25         | Amaryllis      | 31                           | Grandfather's Clock | 02              | Stutter (rapid intermittent horn) | 08                                | Synthesized Bell                  | 14                                | Maiden's Prayer  | 20               | The camptown Races | 26            | Symphony No.40 | 32             | Ave Maria                      | 03                            | Bell (clear highpitched bell) | 09                            | Stutter + Bell                | 15                            | Minuet | 21              | Cuckoo            | 27                 | Silent Lakeside                   |             |                          | 04                     | Yelp (rapid siren) | 10                 | Synthesized Melody Chime | 16                       | Annie Laurie | 22                       | Blacksmith in the village | 28               | Mountain musician |              |                          | 05                 | Rapid Hi-Lo | 11          | Chime       | 17          | London bridge is falling down | 23                    | On the Avignon bridge       | 29                | Romance De Amour    |            |                      | 06        | Melody Chime | 12           | Call sign    | 18           | Holdiridia     | 24                 | Daydream Believer  | 30                               | Petrouchka      |                  |               |                |  |  |
|       | Ctype | 01                            | Beep (slow intermittent horn) | 07                            | Synthesized Piano             | 13                | Can't Take My Eyes off of You | 19                     | Canon      | 25             | I Don't Want to Miss a Thing | 31                  | Imasugu Kisu Mi | 02                                | Stutter (rapid intermittent horn) | 08                                | Synthesized Bell                  | 14               | Top of the World | 20                 | Rara Sanshain | 26             | Yozorano Mukou | 32                             | Haruyo Koi                    | 03                            | Bell (clear highpitched bell) | 09                            | Stutter + Bell                | 15     | The Entertainer | 21                | Uchuusenkan Yamato | 27                                | Aiwa Katsu  |                          |                        | 04                 | Yelp (rapid siren) | 10                       | Synthesized Melody Chime | 16           | Amazing Grace            | 22                        | Oshiete          | 28                | Truth        |                          |                    | 05          | Rapid Hi-Lo | 11          | Chime       | 17                            | Amalrono Kamino Otome | 23                          | Makenaide         | 29                  | Gattsudaze |                      |           | 06           | Melody Chime | 12           | Call sign    | 18             | Les Champs-Elysees | 24                 | Gonna Fly Now(Theme for "Rocky") | 30              | Odoru Ponpokorin |               |                |  |  |
|       |       | Dtype                         | 01                            | Beep (slow intermittent horn) | 07                            | Synthesized Piano | 13                            | Oribiao Kikinagara     | 19         | Happy Birthday | 25                           | Wiegenlied          | 31              | When the Saints Go Marching In    | 02                                | Stutter (rapid intermittent horn) | 08                                | Synthesized Bell | 14               | A September        | 20            | Hi Ho          | 26             | Rudolph the Red-nosed Reindeer | 32                            | Londonderry Air               | 03                            | Bell (clear highpitched bell) | 09                            | Chime  | 15              | Doyoubino Koibito | 21                 | I've been working on the Railroad | 27          | She Wore a Yellow Ribbon |                        |                    | 04                 | Yelp (rapid siren)       | 10                       | Call sign    | 16                       | Akino Kehai               | 22               | Bear Song         | 28           | Oh My Darling Clementine |                    |             | 05          | Rapid Hi-Lo | 11          | Runner                        | 17                    | Saafu Tengoku Sukii Tengoku | 23                | Toys Go Cha Cha Cha | 29         | Yellow Rose of Texas |           |              | 06           | Melody Chime | 12           | Mamotte Agetai | 18                 | Iro Howaitoburendo | 24                               | Konnako Irukana | 30               | Yankee Doodle |                |  |  |
|       |       |                               | Etype                         | 01                            | Beep (slow intermittent horn) | 07                | Synthesized Piano             | 13                     | Train Ride | 19             | Ringin Phone                 | 25                  | Annie Laurie    | 31                                | Ave Maria                         | 02                                | Stutter (rapid intermittent horn) | 08               | Synthesized Bell | 14                 | Gallop Hi-Lo  | 20             | Two Tone       | 26                             | London bridge is falling down | 32                            | Grandfather's Clock           | 03                            | Bell (clear highpitched bell) | 09     | Stutter + Bell  | 15                | Alien Chatter      | 21                                | Alarm Clock | 27                       | Mary had a little Lamb |                    |                    | 04                       | Yelp (rapid siren)       | 10           | Synthesized Melody Chime | 16                        | Falling Crystals | 22                | Ringin Hi-Lo | 28                       | The camptown Races |             |             | 05          | Rapid Hi-Lo | 11                            | Chime                 | 17                          | Inverted Revellie | 23                  | Fur Elise  | 29                   | Amaryllis |              |              | 06           | Melody Chime | 12             | Call sign          | 18                 | Galactic Motor                   | 24              | Minuet           | 30            | Symphony No.40 |  |  |

## Sound groups

| Sound Groups | Sound type · CH |                               |                                   |                                |                                   |                               |                                   |                                   |  |
|--------------|-----------------|-------------------------------|-----------------------------------|--------------------------------|-----------------------------------|-------------------------------|-----------------------------------|-----------------------------------|--|
|              | Group A         | Group B                       | Group C                           | Group D                        | Group E                           | Group F                       | Group G                           | Group H                           |  |
| Atype        | CH1             | Fur Elise                     | Mary had a little Lamb            | Amaryllis                      | Grandfather's Clock               | Romance De Amour              | Mary had a little Lamb            | Beep (slow intermittent horn)     | Binary mode<br><br>Sound 1-32 can be selected by using CH1-CH6 |
|              | CH2             | Maiden's Prayer               | The camptown Races                | Symphony No.40                 | Ave Maria                         | The camptown Races            | Symphony No.40                    | Stutter (rapid intermittent horn) |  |
|              | CH3             | Minuet                        | Cuckoo                            | Silent Lakeside                | Daydream Believer                 | Minuet                        | Holdiridia                        | Bell (clear highpitched bell)     |  |
|              | CH4             | Annie Laurie                  | Blacksmith in the village         | Mountain musician              | London bridge is falling down     | Ave Maria                     | Daydream Believer                 | Yelp (rapid siren)                |  |
|              | CH5             | London bridge is falling down | On the Avignon bridge             | Romance De Amour               | Bell (clear highpitched bell)     | Stutter + Bell                | Rapid Hi-Lo                       | Rapid Hi-Lo                       |  |
|              | CH6             | Holdiridia                    | Daydream Believer                 | Petrouchka                     | Yelp (rapid siren)                | Synthesized Melody Chime      | Melody Chime                      | Melody Chime                      |  |
|              | CH7             | Chime                         | Chime                             | Chime                          | Synthesized Piano                 | Synthesized Piano             | Synthesized Piano                 | Synthesized Piano                 |  |
|              | CH8             | Call sign                     | Call sign                         | Call sign                      | Synthesized Bell                  | Synthesized Bell              | Synthesized Bell                  | Synthesized Bell                  |  |
| Ctype        | CH1             | Can't Take My Eyes off of You | Canon                             | I Don't Want to Miss a Thing   | Imasugu Kisu Mi                   | Amalrono Kamino Otome         | Beep (slow intermittent horn)     | Odoru Ponpokorin                  | Binary mode<br><br>Sound 1-32 can be selected by using CH1-CH6 |
|              | CH2             | Top of the World              | Rara Sanshain                     | Yozorano Mukou                 | Haruyo Koi                        | Makenaide                     | Stutter (rapid intermittent horn) | Aiwa Katsu                        |  |
|              | CH3             | The Entertainer               | Uchuusenkan Yamato                | Aiwa Katsu                     | Uchuusenkan Yamato                | Gattsudaze                    | Stutter + Bell                    | Truth                             |  |
|              | CH4             | Amazing Grace                 | Oshiete                           | Truth                          | Rara Sanshain                     | Top of the World              | Synthesized Melody Chime          | Les Champs-Elysees                |  |
|              | CH5             | Amalrono Kamino Otome         | Makenaide                         | Gattsudaze                     | Can't Take My Eyes off of You     | Canon                         | Synthesized Piano                 | Amazing Grace                     |  |
|              | CH6             | Les Champs-Elysees            | Gonna Fly Now(Theme for "Rocky")  | Odoru Ponpokorin               | Gonna Fly Now(Theme for "Rocky")  | Haruyo Koi                    | Synthesized Bell                  | Yozorano Mukou                    |  |
|              | CH7             | Chime                         | Chime                             | Chime                          | Chime                             | Chime                         | Chime                             | Chime                             |  |
|              | CH8             | Call sign                     | Call sign                         | Call sign                      | Call sign                         | Call sign                     | Call sign                         | Call sign                         |  |
| Dtype        | CH1             | Runner                        | HAPPY BIRTHDAY                    | She Wore a Yellow Ribbon       | Yellow Rose of Texas              | Runner                        | Saafu Tengoku Sukii Tengoku       | Doyoubino Koibito                 | Binary mode<br><br>Sound 1-32 can be selected by using CH1-CH6 |
|              | CH2             | Mamotte Agetai                | Hi Ho                             | Oh My Darling Clementine       | Yankee Doodle                     | Iro Howaitoburendo            | Konnako Irukana                   | I've been working on the Railroad |  |
|              | CH3             | Oribiao Kikinagara            | I've been working on the Railroad | Yellow Rose of Texas           | When the Saints Go Marching In    | Wiegenlied                    | Oribiao Kikinagara                | She Wore a Yellow Ribbon          |  |
|              | CH4             | A September                   | Bear Song                         | Yankee Doodle                  | Londonderry Air                   | Hi Ho                         | Rudolph the Red-nosed Reindeer    | Yankee Doodle                     |  |
|              | CH5             | Doyoubino Koibito             | Toys Go Cha Cha Cha               | When the Saints Go Marching In | Beep (slow intermittent horn)     | Bell (clear highpitched bell) | Rapid Hi-Lo                       | Synthesized Piano                 |  |
|              | CH6             | Akino Kehai                   | Konnako Irukana                   | Londonderry Air                | Stutter (rapid intermittent horn) | Yelp (rapid siren)            | Melody Chime                      | Synthesized Bell                  |  |
|              | CH7             | Saafu Tengoku Sukii Tengoku   | Wiegenlied                        | Runner                         | Chime                             | Chime                         | Chime                             | Chime                             |  |
|              | CH8             | Iro Howaitoburendo            | Rudolph the Red-nosed Reindeer    | Mamotte Agetai                 | Call sign                         | Call sign                     | Call sign                         | Call sign                         |  |
| Etype        | CH1             | Fur Elise                     | Minuet                            | Fur Elise                      | Alien Chatter                     | Train Ride                    | Rapid Hi-Lo                       | Beep (slow intermittent horn)     | Binary mode<br><br>Sound 1-32 can be selected by using CH1-CH6 |
|              | CH2             | Minuet                        | Annie Laurie                      | London bridge is falling down  | Falling Crystals                  | Gallop Hi-Lo                  | Chime                             | Stutter (rapid intermittent horn) |  |
|              | CH3             | Annie Laurie                  | Amaryllis                         | Mary had a little Lamb         | Inverted Revellie                 | Inverted Revellie             | Stutter (rapid intermittent horn) | Bell (clear highpitched bell)     |  |
|              | CH4             | London bridge is falling down | Symphony No.40                    | The camptown Races             | Galactic Motor                    | Galactic Motor                | Ringin Phone                      | Yelp (rapid siren)                |  |
|              | CH5             | Mary had a little Lamb        | Grandfather's Clock               | Amaryllis                      | Ringin Phone                      | Alarm Clock                   | Stutter + Bell                    | Rapid Hi-Lo                       |  |
|              | CH6             | The camptown Races            | Ave Maria                         | Grandfather's Clock            | Two Tone                          | Ringin Hi-Lo                  | Synthesized Melody Chime          | Melody Chime                      |  |
|              | CH7             | Chime                         | Chime                             | Chime                          | Alarm Clock                       | Synthesized Piano             | Synthesized Piano                 | Synthesized Piano                 |  |
|              | CH8             | Call sign                     | Call sign                         | Call sign                      | Ringin Hi-Lo                      | Synthesized Bell              | Synthesized Bell                  | Synthesized Bell                  |  |

※Factory default setting(groupA)

RT-FC015-A18A-2.3

**PATLITE Corporation**

| 指定公差                        | 角度公差              | 寸法公差                     | 符号   | 年月日  | 訂正履歴      | 記印   | 検印   | 承認   |
|-----------------------------|-------------------|--------------------------|------|------|-----------|------|------|------|
| General tolerance           | Angular tolerance | Dimensional tolerance    | Sym. | Date | Revisions | Sgn. | Chk. | App. |
| 短辺長<br>Length of short side | ~                 | 6 30 120 300 1000        | △-   |      |           |      |      |      |
| 精 f                         | 10 50 100         | 精 f 0.05 0.1 0.2 0.4 0.6 | △-   |      |           |      |      |      |
| 中 m                         | 1 0.5 0.3 0.1     | 中 m 0.1 0.3 0.5 0.7 1    | △-   |      |           |      |      |      |
| 粗 v                         | 3 1.5 1 0.5       | 粗 c 0.3 0.5 1 1.2 2      | △-   |      |           |      |      |      |

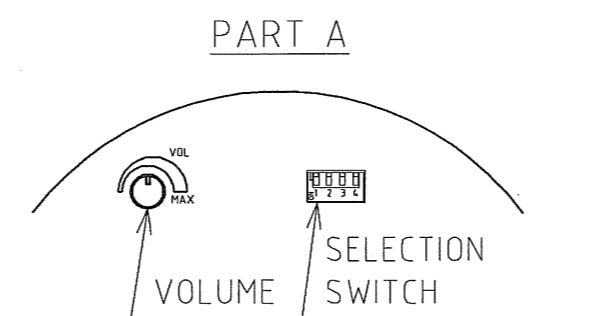
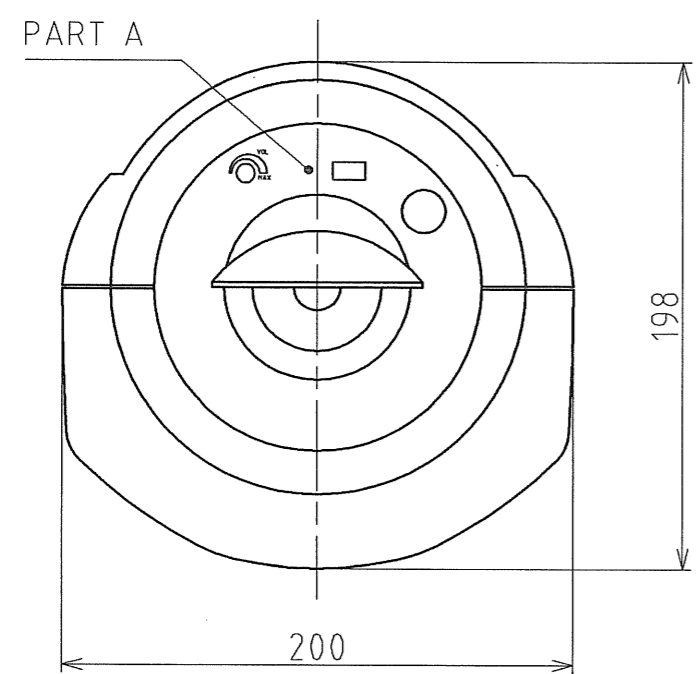

- THE FUNCTION LIST OF SELECTON SWITCH
- |   |   |
|---|---|
| 1 | SELECT THE SOUND GROUPS OF "H" FROM "A" |
| 2 | TEST PLAY                               |

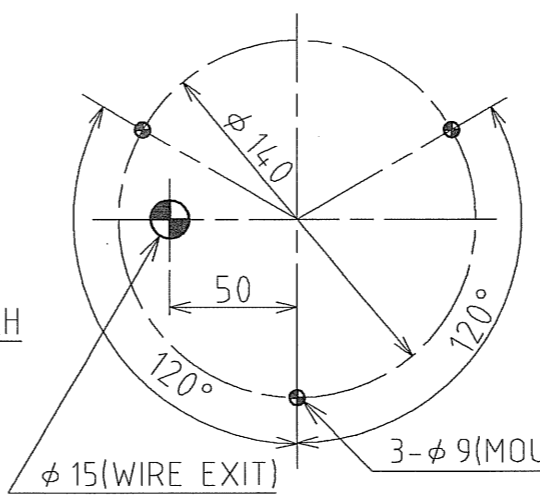

FRONT DIRECTION  
MOUNTING SURFACE DIMENSIONS

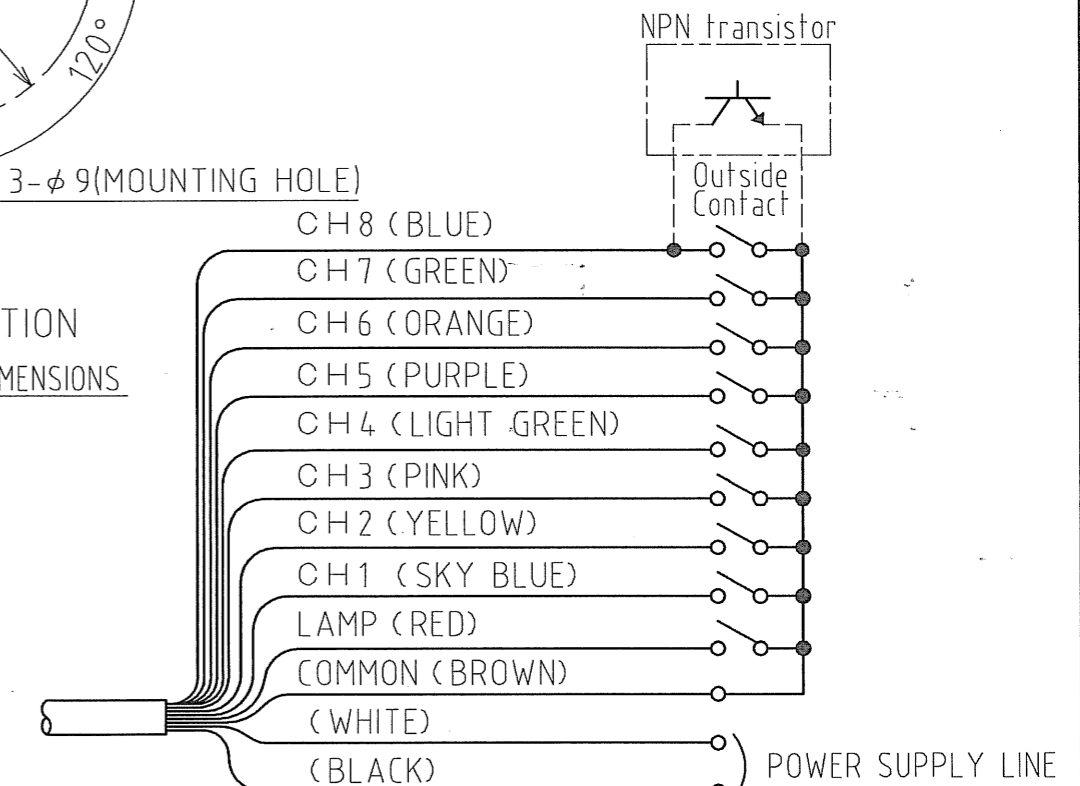

(REGARDING RT-24□, CONNECT THE POWER SUPPLY LINE(BLACK) AT THE MINUS.)

WIRING

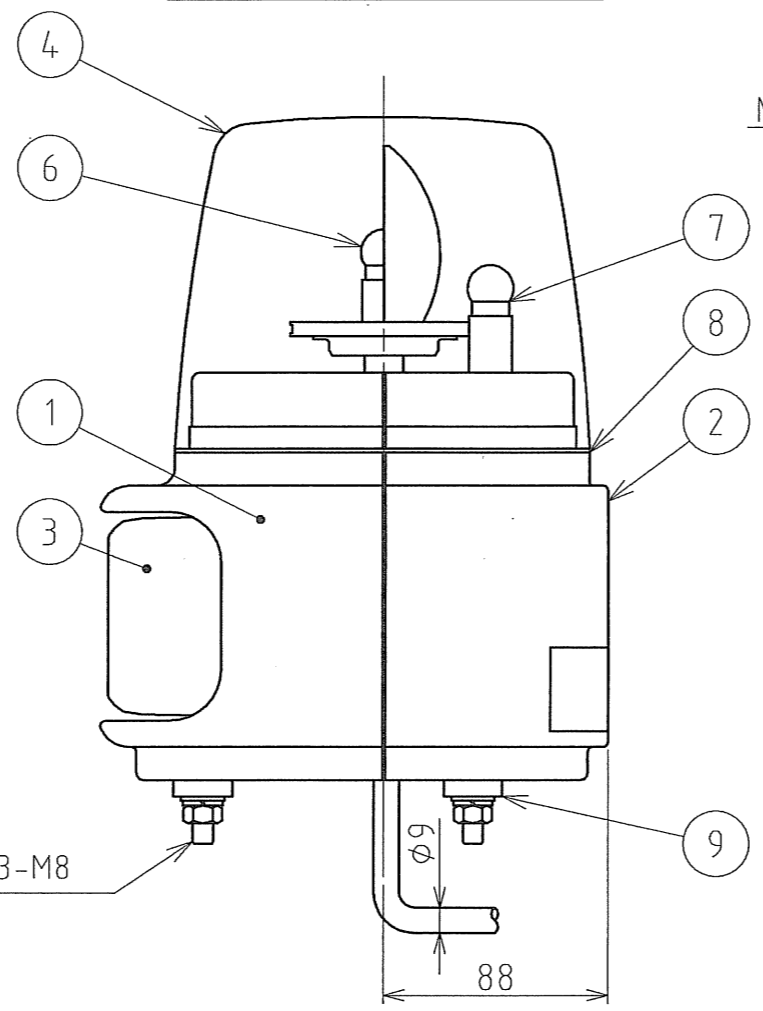
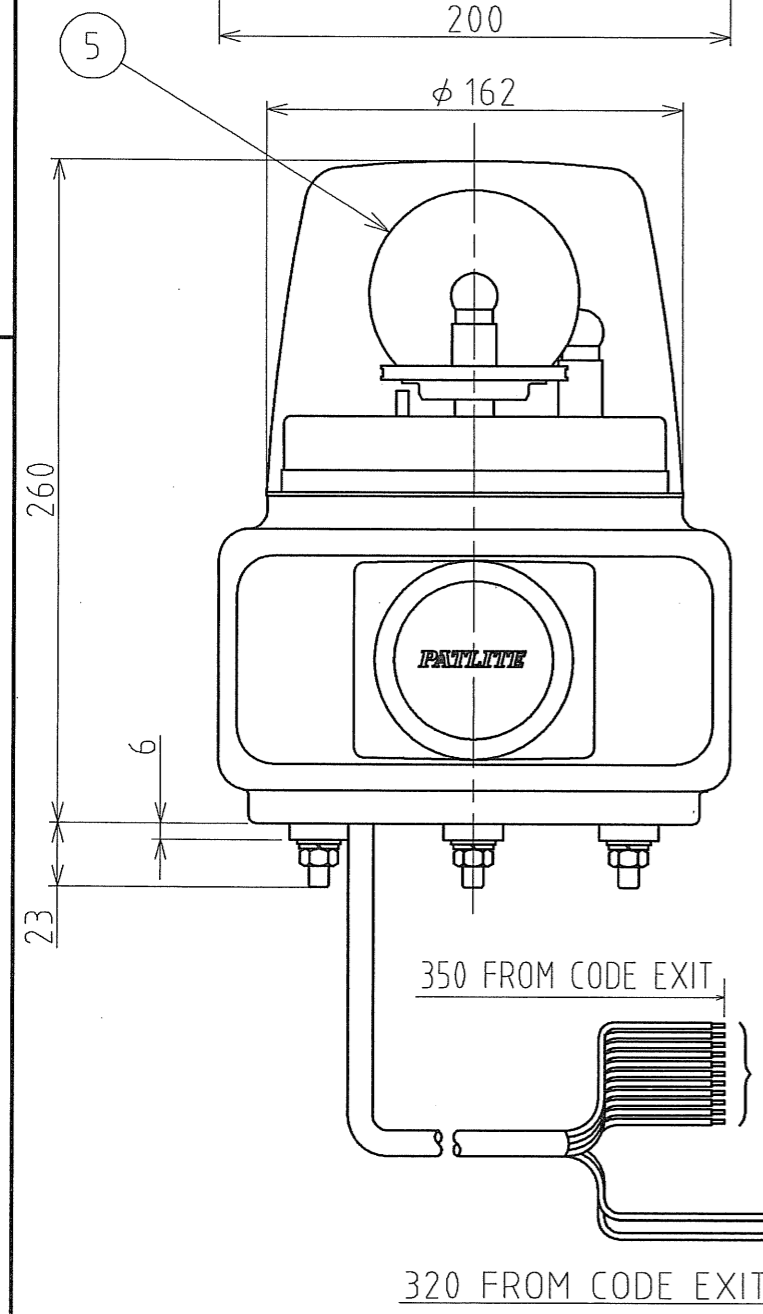

| 番号 No. | 部品名 Part Name   | 品目コード Part No. | 数量 Qty. | 材料 & 寸法 & 処理 Material & Size & Finish | 記事 Remarks |
|--------|-----------------|----------------|---------|---------------------------------------|------------|
| 9      | CUSHION RUBBERS |                | 3       | EPDM                                  | Black      |
| 8      | GASKET          |                | 1       | EPDM                                  | Black      |
| 7      | SPARE BULB      |                | 1       | Ref. Specifications                   |            |
| 6      | BULB            |                | 1       | Ref. Specifications                   |            |
| 5      | REFLECTOR       |                | 1       | PC                                    |            |
| 4      | DOME            |                | 1       | AS                                    |            |
| 3      | HORN            |                | 1       | ABS                                   | Light Gray |
| 2      | BODY B          |                | 1       | ABS                                   | Light Gray |
| 1      | BODY A          |                | 1       | ABS                                   | Light Gray |

| 設計 Dgn.by        | 製図 Drn.by  | 検図 Chk.by  | 承認 App.by  | 図名 Name                        | 機種名 Model      | 特注 No. S.P.No.    |
|------------------|------------|------------|------------|--------------------------------|----------------|-------------------|
| T.Fujiwara       | T.Fujiwara | M.Yoshida  | M.Yoshida  | SPECIFICATION(3/3)             | #RT-□□□A/C/D/E | FC015             |
| 16.Nov.'09       | 29.Dec.'09 | 29.Dec.'09 | 29.Dec.'09 | Dimensional Drawing            | 品目コード Part No. |                   |
| 三角法 3rd Angle P. | 単位 Unit mm | 尺度 Scale   |            | 株式会社 パトライト PATLITE Corporation | 図番 Drawing No. | RT-FC015-A18A-3_3 |