

Siemens STEP 2000 Course



Motor Control Centers

It's easy to get in STEP!

- 1 Download any course.
Hint: Make sure you download all parts for each course and the test answer form.
- 2 Complete each chapter and its review section
- 3 Print the test answer form, take the final exam and fill in the form.
Hint: The final exam is always at the end of the last part.
- 4 Send your test answer form to EandM for grading. If you achieve a score of 70% or better, we'll send you a certificate of completion! If you have any questions, contact EandM Training at 866.693.2636 or fax 707.473.3190 or training@eandm.com.

Need more information? Contact **EandM** at
866.693.2636
or fax 707.473.3190
or sales@eandm.com
for product information, quotes,
classroom training courses and more.

STEP 2000 Courses distributed by
www.eandm.com



SIEMENS

STEP 2000

Motor Control Centers

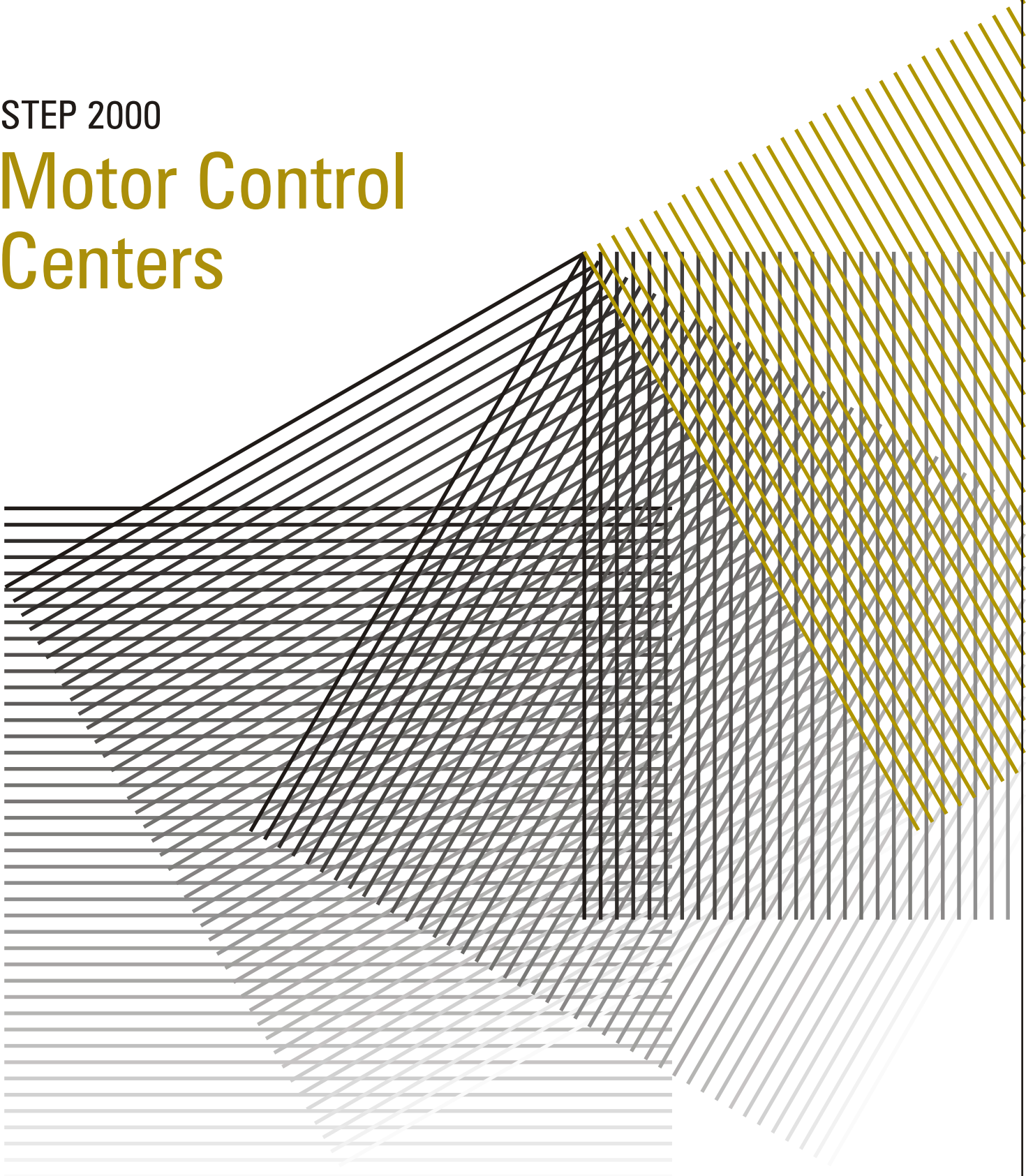

Table of Contents

Introduction	2
Motor Control	4
Power Supplies	8
Design Standards	13
Need for Circuit Protection	14
Overcurrent-Protection Devices.....	19
Motor Control Centers.....	23
Combination Motor Control Units.....	29
Motor Starters	33
Pilot Devices	38
Circuit Breakers	40
Other Types of Units in MCCs	42
MCC Ratings	47
Enclosures	50
Classification and Types of Wiring.....	53
Cable Entry	58
TIASTAR.....	62
Information Needed to Order MCCs	72
Review Answers.....	75
Final Exam	76

Introduction

Welcome to another course in the STEP 2000 series, **Siemens Technical Education Program**, designed to prepare our distributors to sell Siemens Energy & Automation products more effectively. This course covers **Motor Control Centers**.

Upon completion of **Motor Control Centers**, you should be able to:

- Explain the role of motor control centers in a distribution system
- Define a motor control center according to NEMA and UL
- Explain the need for circuit protection
- Identify various components of a motor control center
- Explain the difference between the various classifications and types of motor control center wiring
- Explain features of the TIASTAR motor control centers

This knowledge will help you better understand customer applications. In addition, you will be better prepared to describe motor control products to customers. You should complete **Basics of Electricity** and **Basics of Control Components** before attempting **Motor Control Centers**.

If you are an employee of a Siemens Energy & Automation authorized distributor, fill out the final exam tear-out card and mail in the card. We will mail you a certificate of completion if you score a passing grade. Good luck with your efforts.

Sensitrip is a registered trademark of Siemens Energy & Automation, Inc.

Sentron, ESP100, INNOVA PLUS, TIASTAR, ACCESS, and SAMMS are trademarks of Siemens Energy & Automation, Inc.

National Electrical Code[®] and NEC[®] are registered trademarks of the National Fire Protection Association, Quincy, MA 02269. Portions of the National Electrical Code are reprinted with permission from NFPA 70-2002, National Electrical Code Copyright, 2001, National Fire Protection Association, Quincy, MA 02269. This reprinted material is not the complete and official position of the National Fire Protection Association on the referenced subject which is represented by the standard in its entirety.

Underwriters Laboratories Inc. and UL are registered trademarks of Underwriters Laboratories Inc., Northbrook, IL 60062.

National Electrical Manufacturers Association is located at 2101 L Street, N.W., Washington, D.C. 20037. The abbreviation "NEMA" is understood to mean National Electrical Manufacturers Association.

Other trademarks are the property of their respective owners.

Motor Control

Distribution systems used in large commercial and industrial applications can be complex. Power may be distributed through various switchboards, transformers, and panelboards. Power distributed throughout a commercial or industrial application is used for a variety of applications such as heating, cooling, lighting, and motor-driven machinery.

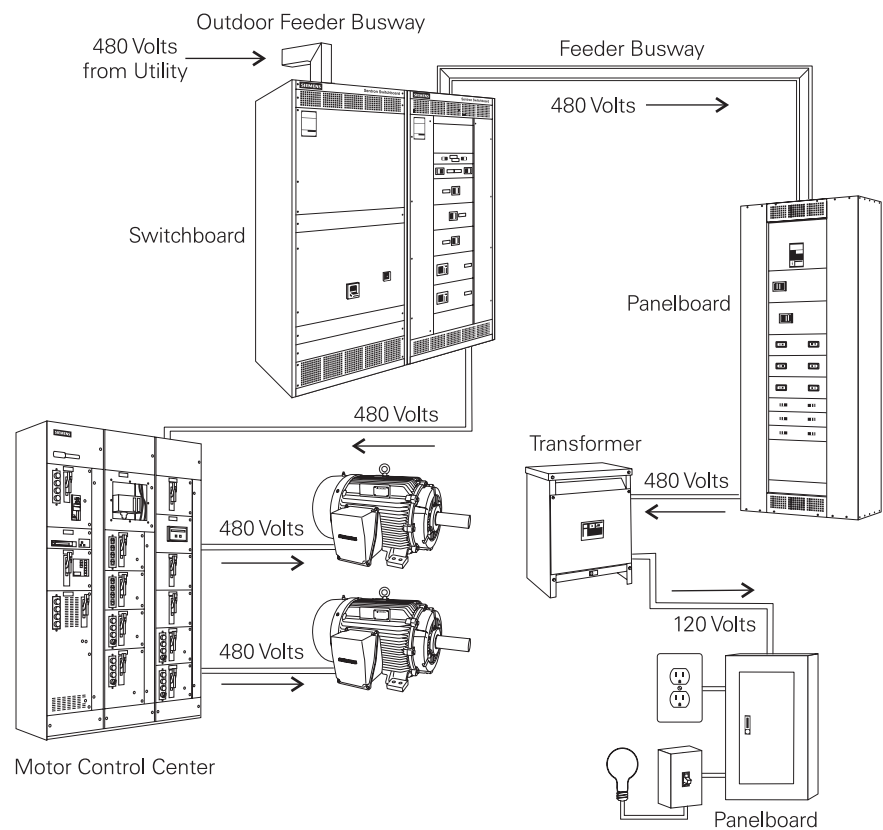

Basic Motor Control

Wherever motors are used, they must be controlled. In **Basics of Control Components** you learned how various control products are used to control the operation of motors. The most basic type of AC motor control, for example, involves turning the motor on and off. This is often accomplished by using a motor starter, which is made up of a contactor and an overload relay. The contactor's contacts are closed to start the motor and opened to stop the motor. This is accomplished electromechanically using start and stop pushbuttons or other pilot devices wired to control the contactor. The overload relay protects the motor by disconnecting power to the motor when an overload condition exists. An overload could occur, for instance, when a conveyor is jammed. Although the overload relay provides protection from overloads, it does not provide short-circuit protection for the wiring providing power to the motor. For this reason, a circuit breaker or fuses are also used.

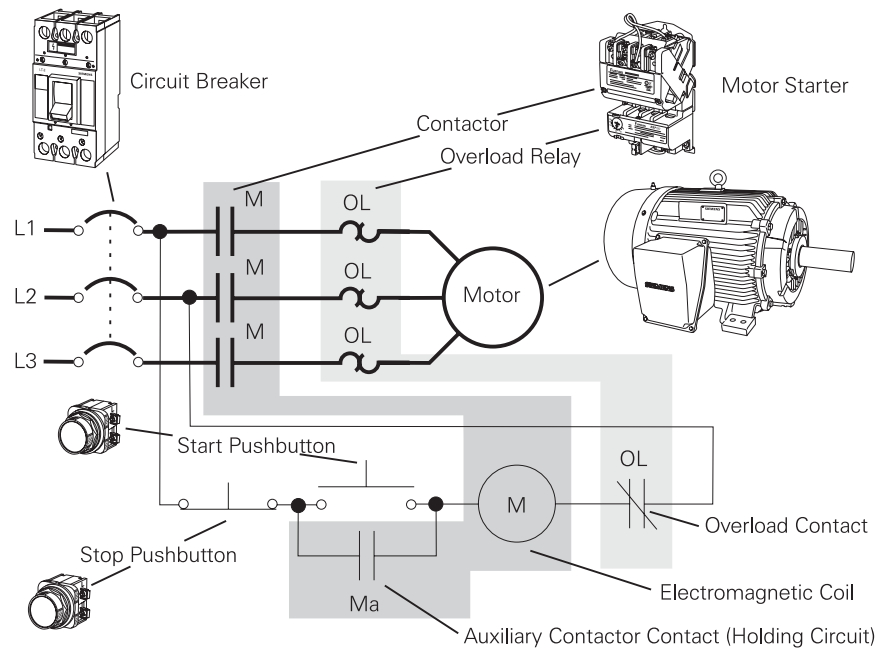

Typically one motor starter controls one motor. When only a few geographically dispersed AC motors are used, the circuit protection and control components may be located in a panel near the motor.

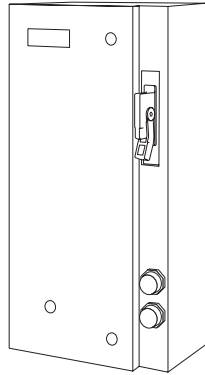

In many commercial and industrial applications quite a few electric motors are required, and it is often desirable to control some or all of the motors from a central location. The apparatus designed for this function is the motor control center (MCC). Motor control centers are simply physical groupings of combination starters in one assembly. A combination starter is a single enclosure containing the motor starter and the fuses or circuit breaker.

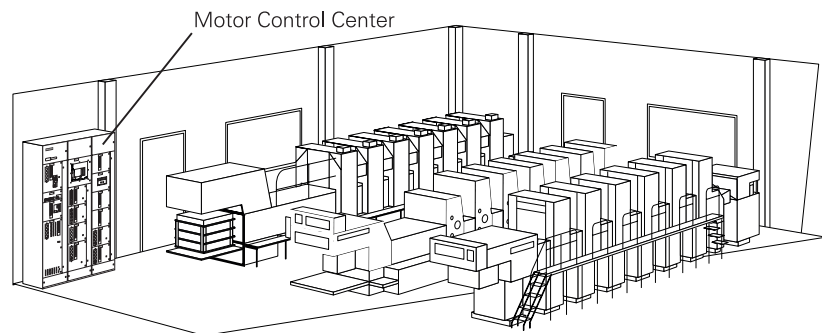

Advantages of Siemens TIASTAR MCCs

TIASTAR™ is the trade name for the Siemens motor control center. Some of the advantages of using TIASTAR are:

- Faster and easier installation and wiring
- Centralized motor control
- Generally less total space is required
- Neat, attractive appearance
- Simplicity in adding special components such as service entrance switches, load centers, and transformers
- Ease of future modifications, such as increasing the size of the starters, adding additional starters, or adding additional vertical sections.

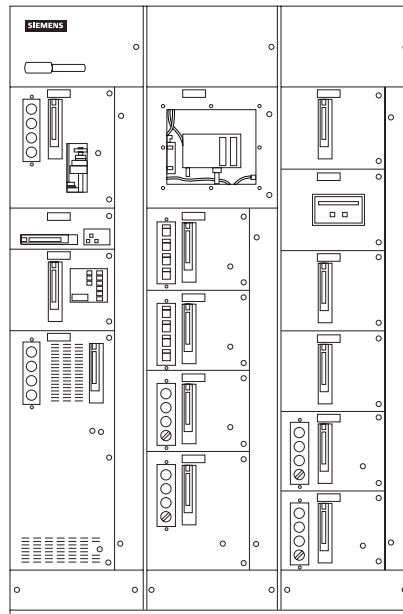

TIASTAR

Power Supplies

The major source of electrical power used by motor control centers is an AC generator located at a power-generating facility. AC generators operate on the theory of electromagnetic induction. This simply means that when conductors are moved through a magnetic field, a voltage is induced into the conductors. A basic generator consists of a magnetic field, an armature, slip rings, brushes, and some type of resistive load. An armature is any number of conductive wires (conductors) wound in loops which rotate through the magnetic field. For simplicity, one loop is shown.

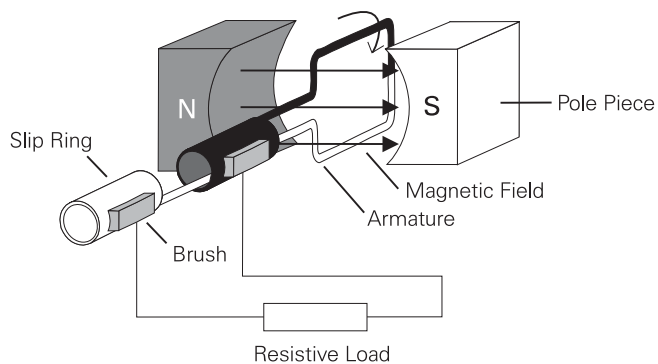

If the rotation of the AC generator were tracked through a complete revolution of 360° , it could be seen that during the first quarter of a revolution voltage would increase until it reached a maximum positive value at 90° . Voltage would decrease during the second quarter of revolution until it reached zero at 180° . During the third quarter of a revolution voltage would increase in the opposite direction until it reached a maximum negative value at 270° . During the last quarter of a revolution voltage would decrease until it reached zero at 360° . This is one complete cycle or one complete alternation between positive and negative.

If the armature of the AC generator were to rotate 3600 times per minute (RPM) we would get 60 cycles of voltage per second, or 60 hertz. Most alternators have more than two poles and one loop of wire. Alternators can have two or three pairs of electromagnetic poles, allowing the AC generator to generate voltage at 60 Hz at slower speeds.

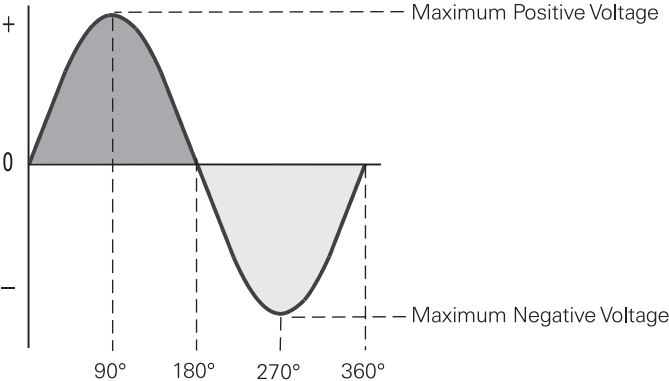

Three-Phase Voltage

In most large commercial and industrial motor applications three-phase voltage is used. In a three-phase system the generator produces three voltages. Each voltage phase rises and falls at the same frequency (60 Hz in the U.S., 50 Hz in many other countries); however, the phases are offset by 120° from each other.

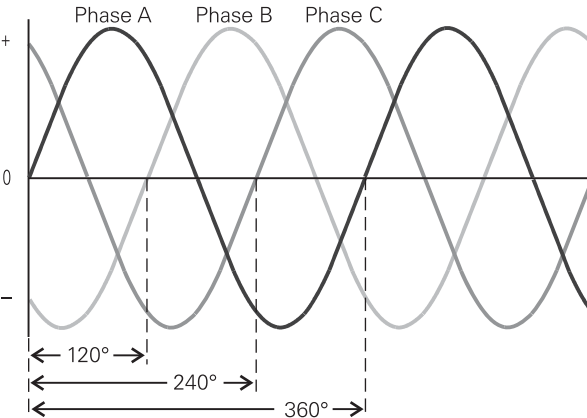

The motor control center receives this power through complex distribution systems which include power distribution lines, transformers, substations, and switchboards. Transformers used with three-phase power require three interconnected coils in both the primary and the secondary. These transformers can be connected in either a wye or a delta configuration. The type of transformer and the actual voltage depend on the requirements and capability of the power company and the needs of the customer. The following illustration shows the secondary of a wye- and delta-connected transformer.

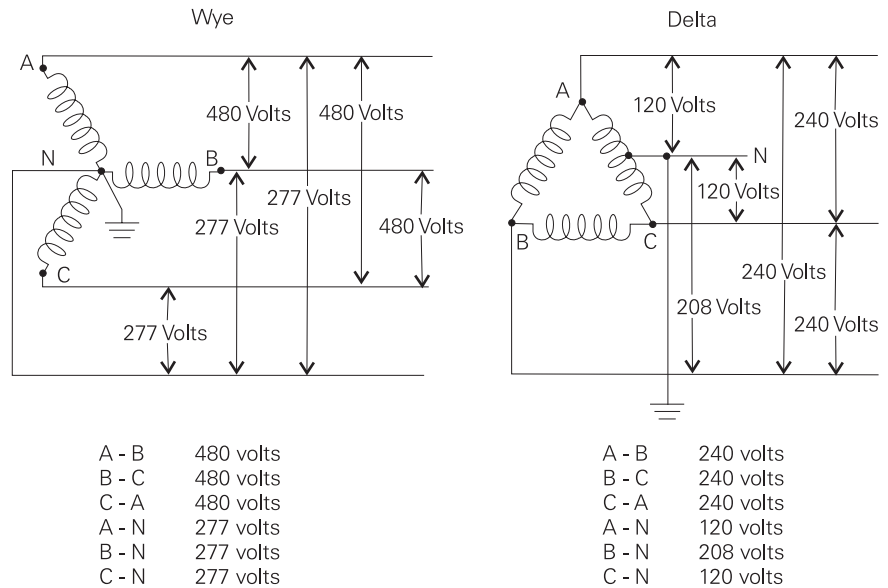

Motor Rotation

Three-phase voltage is used throughout large commercial and industrial facilities to run AC motors. An AC motor is made up of a stationary member, called a stator, and a rotating member, called a rotor. Three-phase AC power is applied to the stator through the power connections.

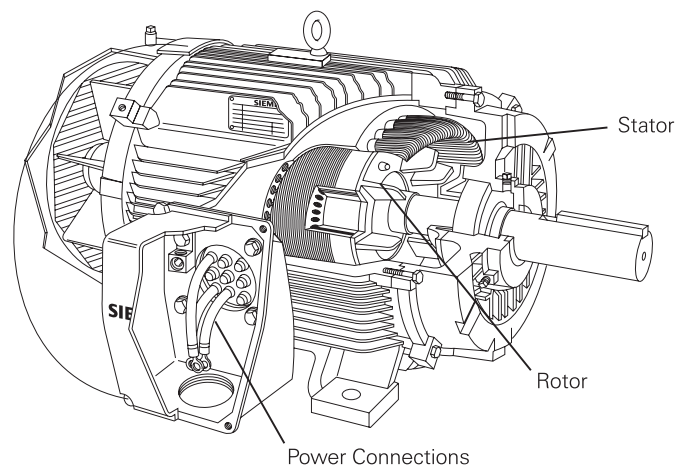

The direction a three-phase AC motor rotates depends on the phase sequence of the incoming power supply. In the following example, L1 (A) is connected to motor lead T1, L2 (B) is connected to motor lead T2, and L3 (C) is connected to motor lead T3. When power is applied through the "F" contacts the motor will turn in a clockwise, or forward direction.

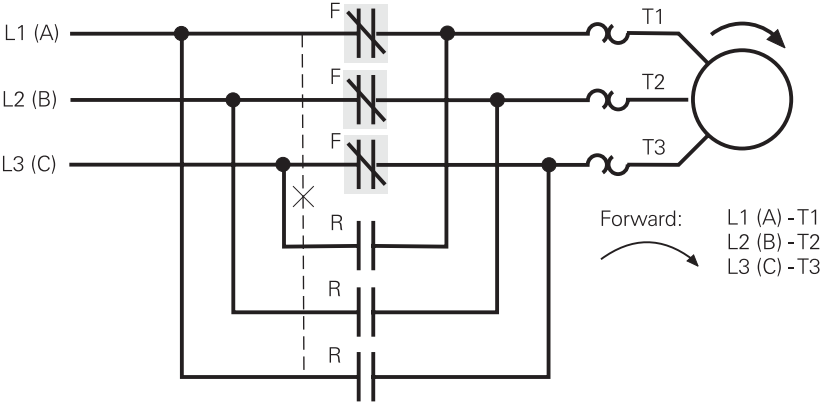

However, by reversing any two of the three power supply leads, the motor will run in the opposite direction. In this example L1 (A) is connected to motor lead T3, L2 (B) is connected to motor lead T2, and L3 (C) is connected to motor lead T1 (L1 and L3 have been reversed). When power is applied through the "R" contacts the motor will run in the counterclockwise, or reverse direction.

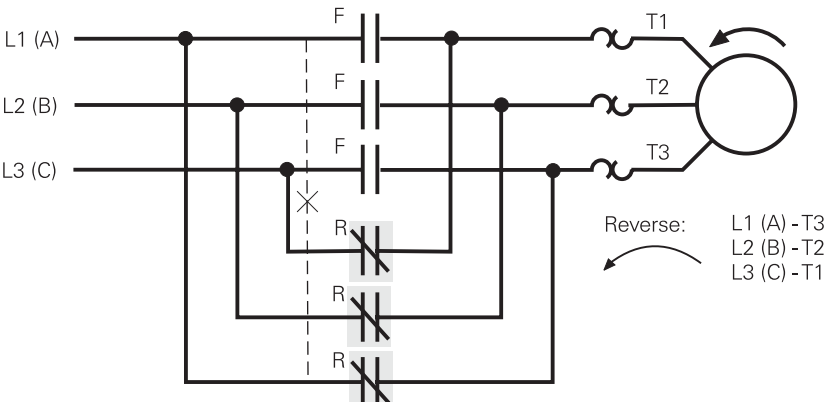

Many applications are designed for forward and reverse operation. An overhead crane, for example, might use the forward direction to raise the crane and reverse direction to lower the crane.

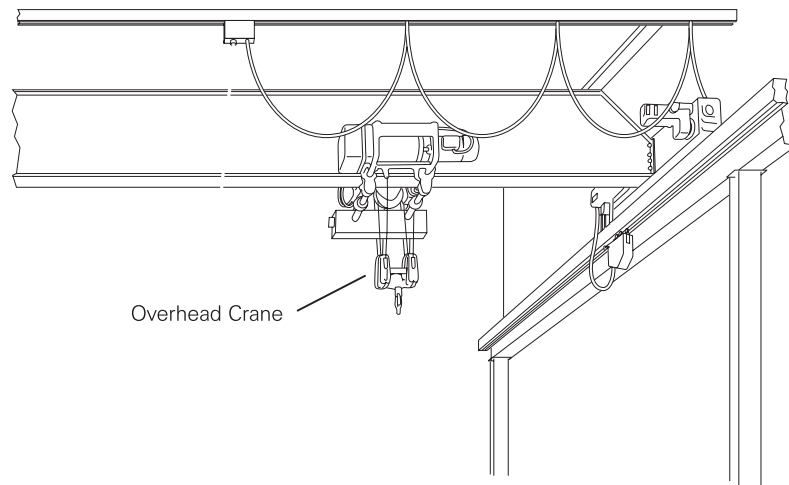

It should be noted that it is not possible to reverse the direction of rotation on some applications. The consequences of running a motor in the reverse direction on an application designed to run only in the forward direction can be disastrous, resulting in equipment damage and possibly injury or loss of life.

Review 1

1. Which of the following is an advantage of using a motor control center?
 - a. Faster and easier installation
 - b. Simplicity in adding special components
 - c. Ease of future modifications
 - d. All the above
2. _____ is the trade name for the motor control center manufactured by Siemens.
3. In most large commercial and industrial motor applications _____ -phase voltage is used.
4. Motor rotation of a three-phase AC motor can be reversed by reversing any _____ of the three power-supply leads.